



6GeV Linac and COLD project: Installation, implementation and safety aspects

(COLD) Cool copper Operation Linac Demonstrator

J. L. Revol

*On behalf of the EBS Accelerator Team and the
international collaboration:
SLAC, INFN, CERN, PSI, CORNELL*

SPACE AVAILABLE FOR COLD

~0.5GeV C³ demonstrator could fit in the empty tunnel and allows independent EBS operation

60m long tunnel

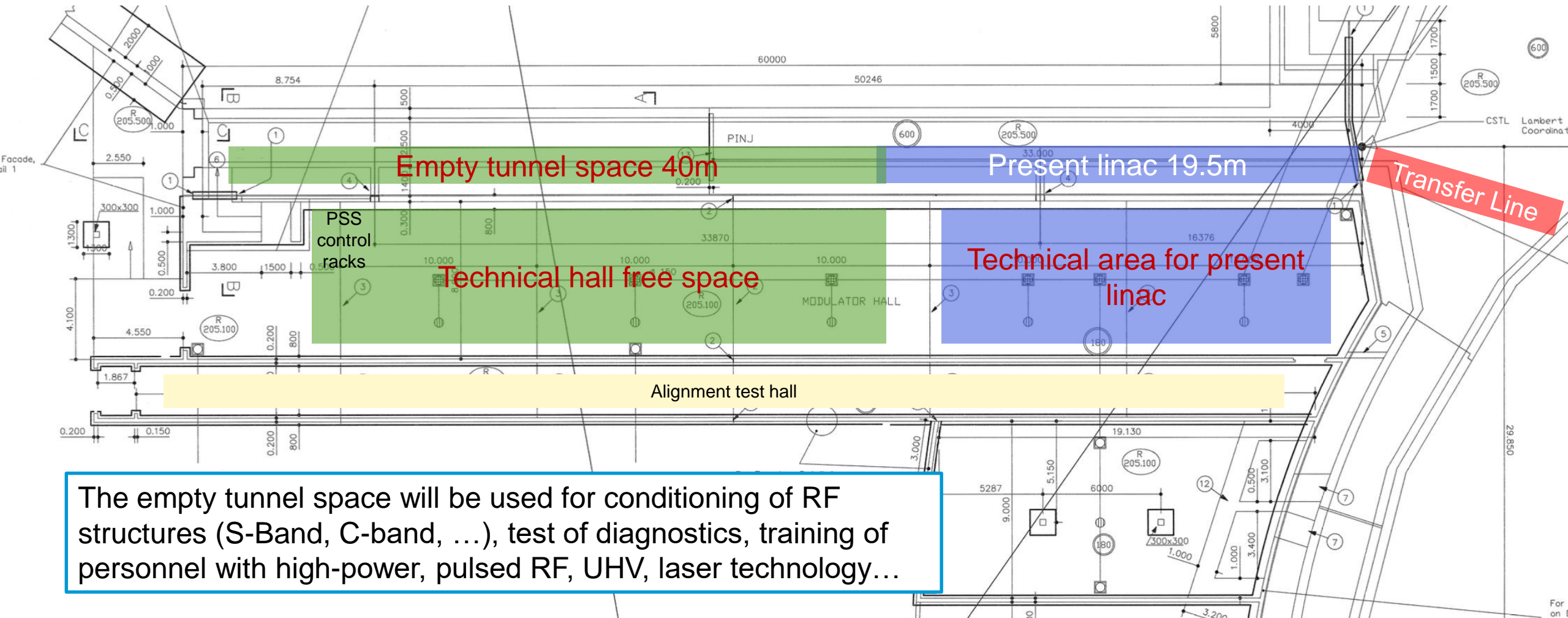

The empty tunnel space will be used for conditioning of RF structures (S-Band, C-band, ...), test of diagnostics, training of personnel with high-power, pulsed RF, UHV, laser technology...

LINAC LAYOUT UNTIL 2025

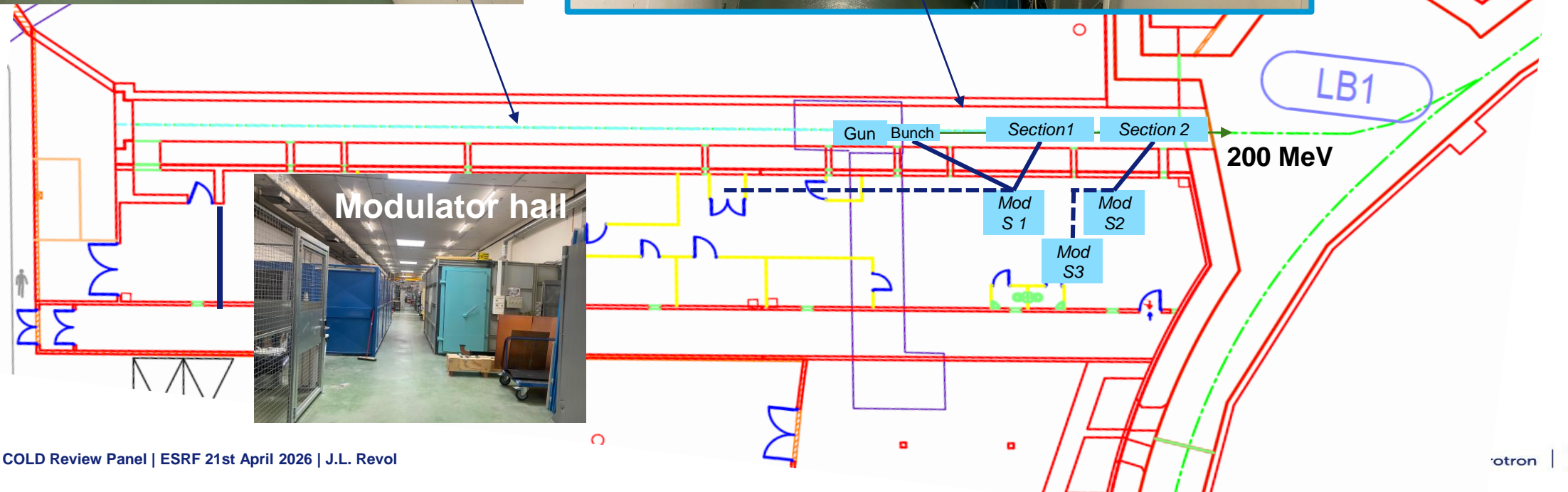

VISIT OF THE PRESENT LINAC (VIDEO)



- ✓ Purchase of accelerating section
- ✓ Purchase of New RF unit with Canon Klystron
- ✓ Displacement of modulator 3
- Hardware update for standalone control of modulator 3
- New RF low level distribution
- Update the SF6 waveguide distribution
- Update the RF waveguide distribution
- ✓ New focusing power supplies for klystron
- Extend the electrical distribution
- Extend ethernet access points
- New Cooling distribution inside/outside tunnel for sections
- ✓ Civil work (Hole, earthing, fence,..)
- Renew/update old equipment (power supplies, electronics, cooling systems, diagnostics, measurements
- Create a new control room

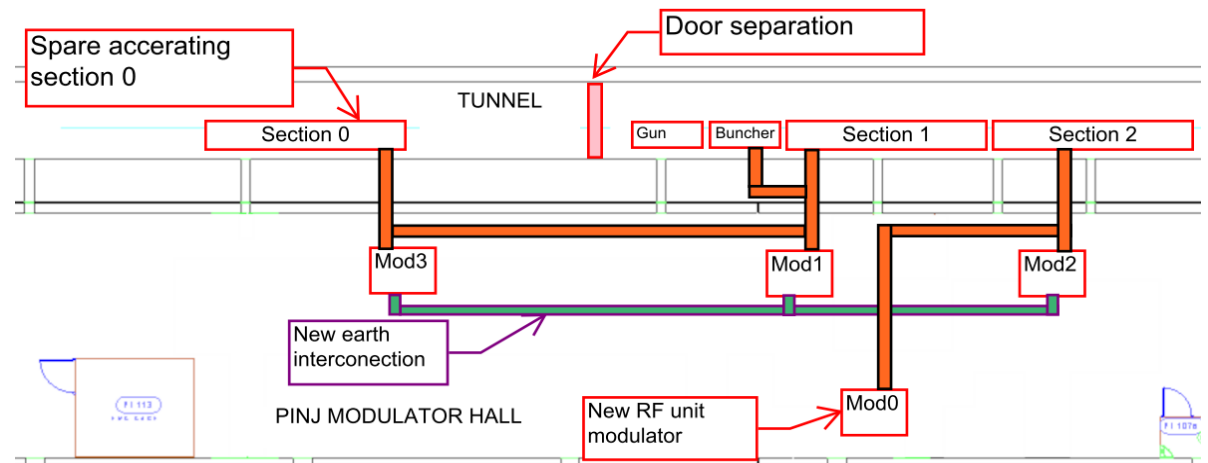
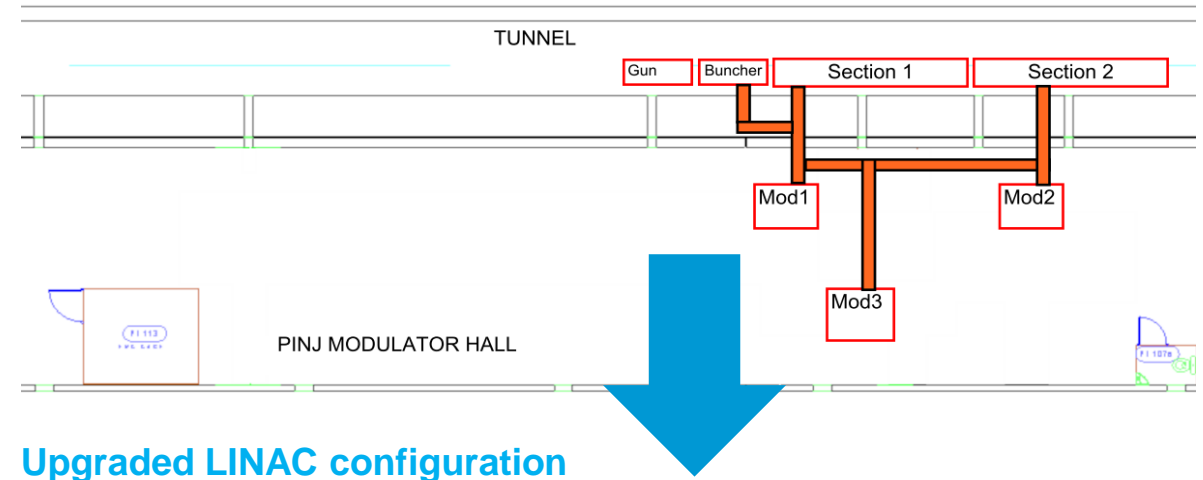

Spare section 0 is delivered, will be installed in the tunnel this summer, conditioned but not tested with beam



New klystron focusing in place

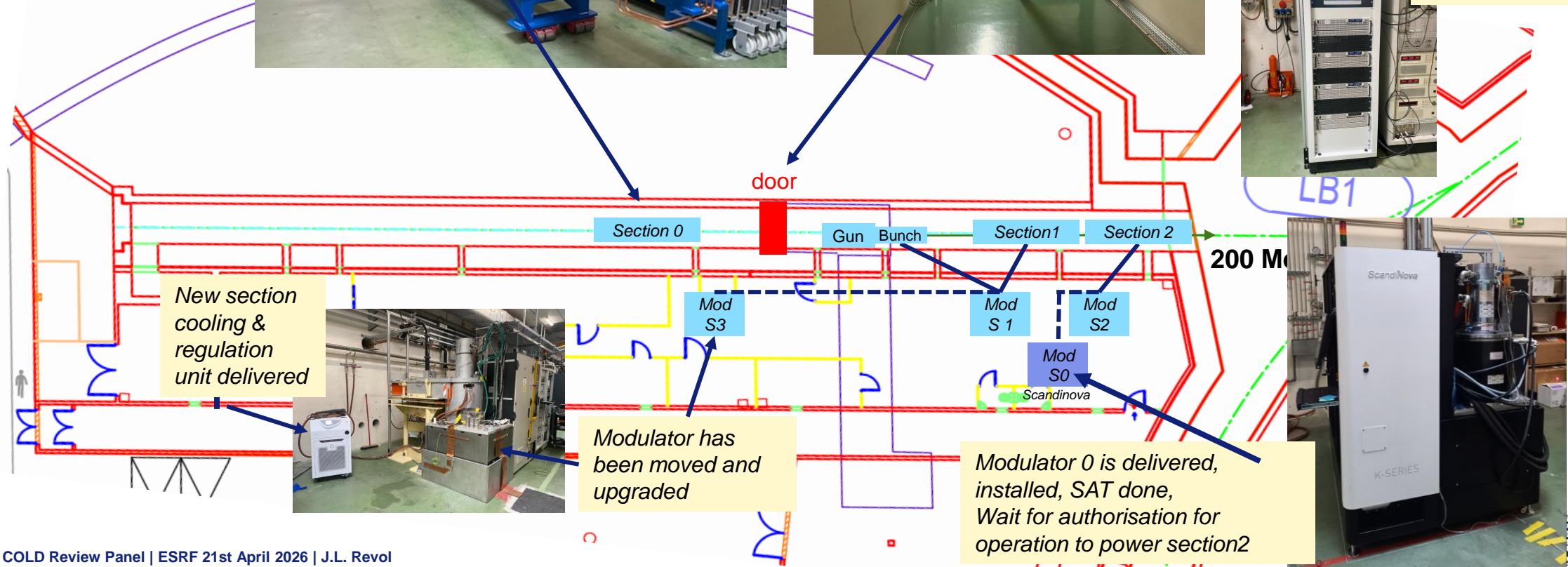

New section cooling & regulation unit delivered



Modulator has been moved and upgraded

Modulator 0 is delivered, installed, SAT done, Wait for authorisation for operation to power section2



C-BAND LINAC ~150-300 MEV PRE-INJECTOR → COLD FINAL OBJECTIVE

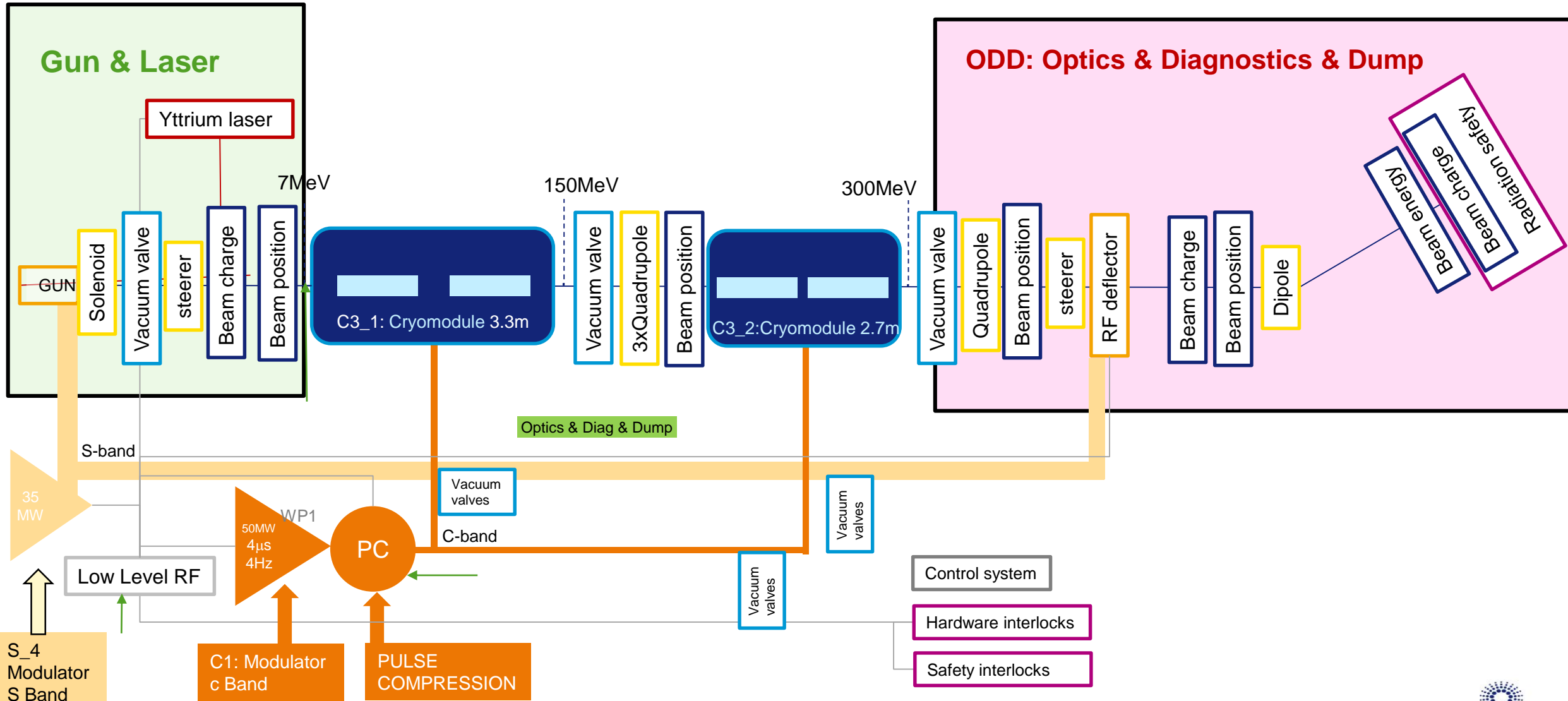

COLD LAYOUT AND PLANNING

Project: COLD Phase 0

Date	Instrument added to the installation	Beam achievements	project
2026-Dec SD	ModS4- RF-unit (SAT)		Phase 0
2027-May SD	First C-band RF-unit		Phase 0
2027-Aug SD	First C-band Acc. Struct.		Phase 0
2028-May SD	Infrastructures installation		Phase 1
2028-May SD	Diagnostics and beam dump		Phase 1
2029-Jan SD	S-band photo-gun + laser	7MeV photogun beam	Phase 1
2029-May SD	Beam in Acc. Struct.	150MeV beam	Phase 1
2030-May SD	RF deflector	2ps bunch length	Phase 1
2029-Dec SD	Second C-band		Phase 2*
2030-Sep		300MeV beam	Phase 2*
2031-Aug SD	TL1 Upgrade and inject in booster	300MeV beam to booster	Phase 3*

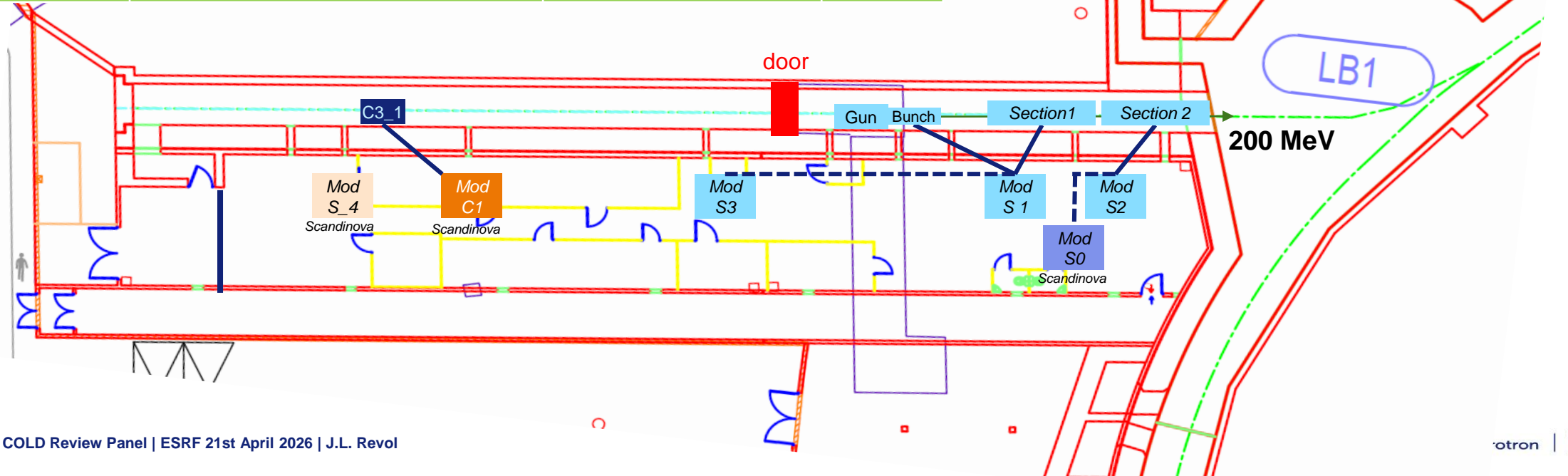

COLD LAYOUT AND PLANNING

Project: COLD Phase 1

Date	Instrument added to the installation	Beam achievements	project
2026-Dec SD	ModS4- RF-unit (SAT)		Phase 0
2027-May SD	First C-band RF-unit		Phase 0
2027-Aug SD	First C-band Acc. Struct.		Phase 0
2028-May SD	Infrastructures installation		Phase 1
2028-May SD	Diagnostics and beam dump		Phase 1
2029-Jan SD	S-band photo-gun + laser	7MeV photogun beam	Phase 1
2029-May SD	Beam in Acc. Struct.	150MeV beam	Phase 1
2030-May SD	RF deflector	2ps bunch length	Phase 1
2029-Dec SD	Second C-band		Phase 2*
2030-Sep		300MeV beam	Phase 2*
2031-Aug SD	TL1 Upgrade and inject in booster	300MeV beam to booster	Phase 3*

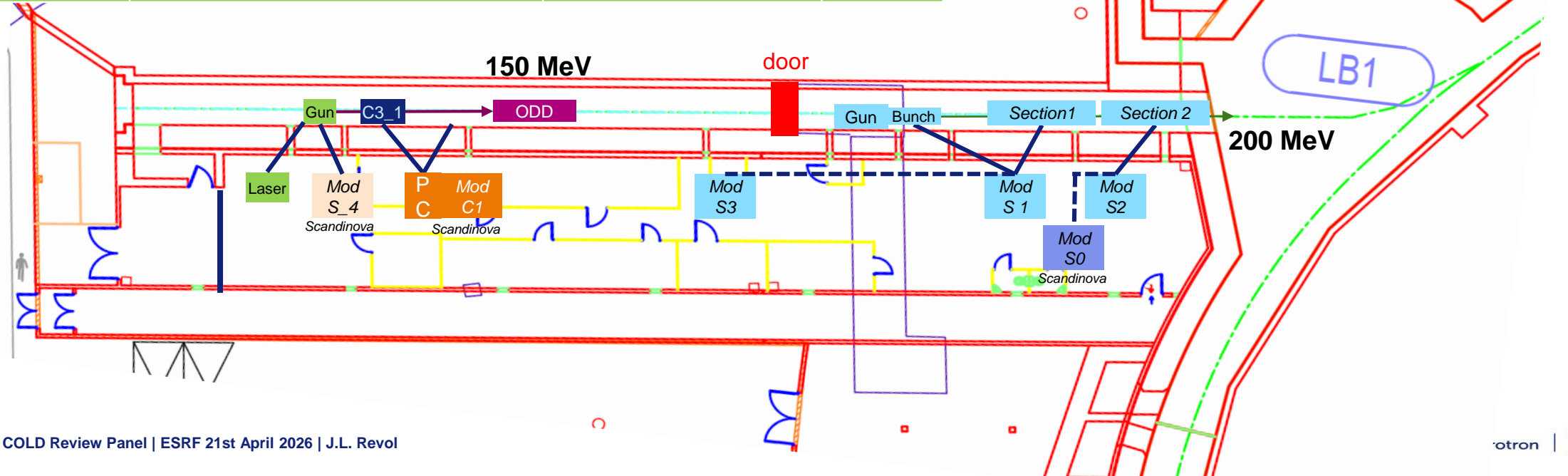

COLD LAYOUT AND PLANNING

Project: COLD Phase 2

Date	Instrument added to the installation	Beam achievements	project
2026-Dec SD	ModS4- RF-unit (SAT)		Phase 0
2027-May SD	First C-band RF-unit		Phase 0
2027-Aug SD	First C-band Acc. Struct.		Phase 0
2028-May SD	Infrastructures installation		Phase 1
2028-May SD	Diagnostics and beam dump		Phase 1
2029-Jan SD	S-band photo-gun + laser	7MeV photogun beam	Phase 1
2029-May SD	Beam in Acc. Struct.	150MeV beam	Phase 1
2030-May SD	RF deflector	2ps bunch length	Phase 1
2029-Dec SD	Second C-band		Phase 2*
2030-Sep		300MeV beam	Phase 2*
2031-Aug SD	TL1 Upgrade and inject in booster	300MeV beam to booster	Phase 3*

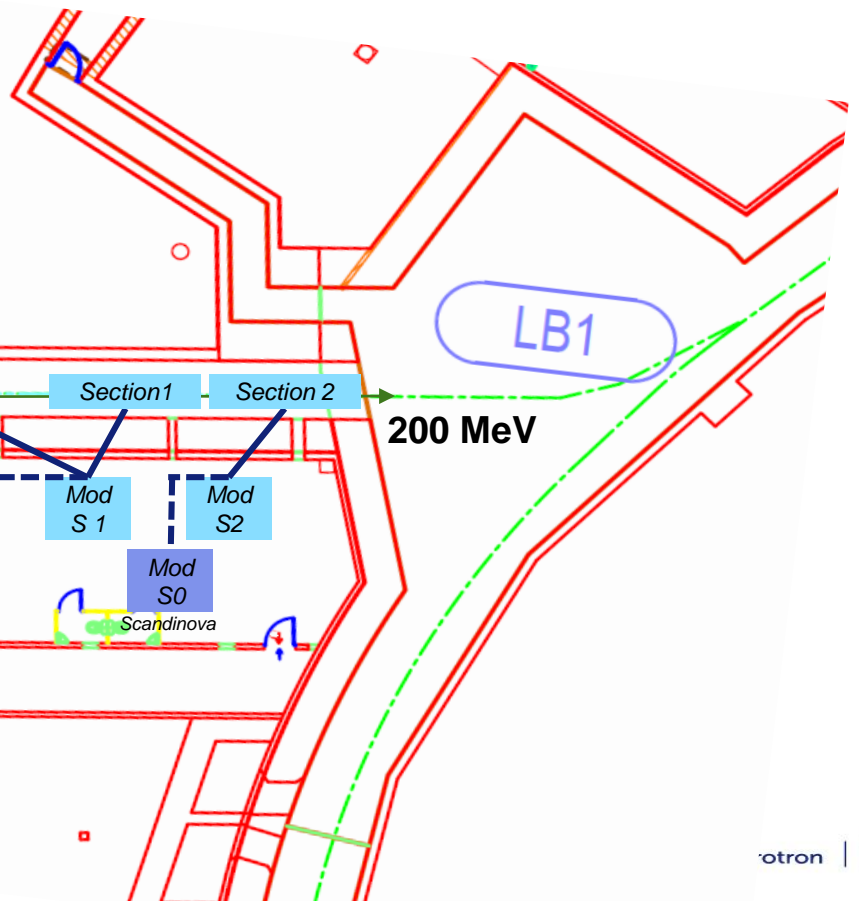

COLD LAYOUT AND PLANNING

Project: COLD Phase 3

Date	Instrument added to the installation	Beam achievements	project
2026-Dec SD	ModS4- RF-unit (SAT)		Phase 0
2027-May SD	First C-band RF-unit		Phase 0
2027-Aug SD	First C-band Acc. Struct.		Phase 0
2028-May SD	Infrastructures installation		Phase 1
2028-May SD	Diagnostics and beam dump		Phase 1
2029-Jan SD	S-band photo-gun + laser	7MeV photogun beam	Phase 1
2029-May SD	Beam in Acc. Struct.	150MeV beam	Phase 1
2030-May SD	RF deflector	2ps bunch length	Phase 1
2029-Dec SD	Second C-band		Phase 2*
2030-Sep		300MeV beam	Phase 2*
2031-Aug SD	TL1 Upgrade and inject in booster	300MeV beam to booster	Phase 3*

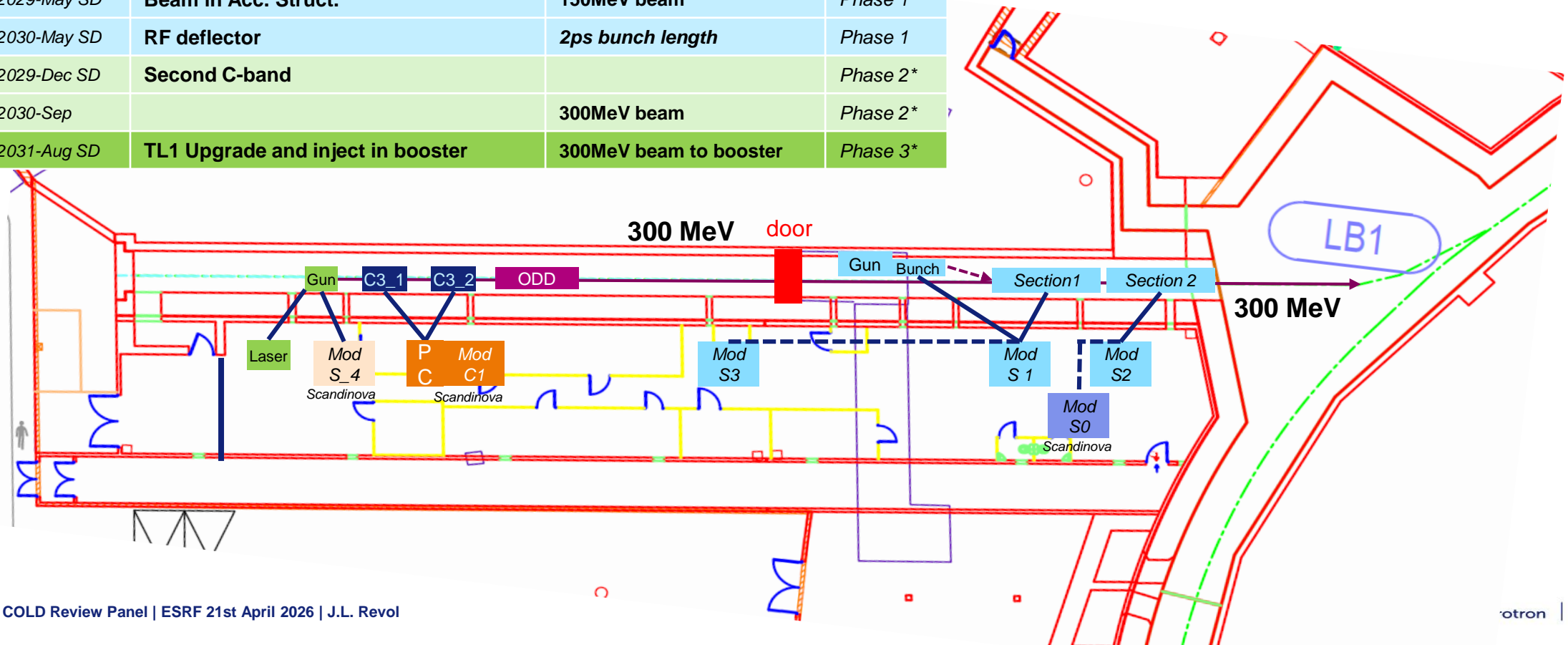

COLD LAYOUT

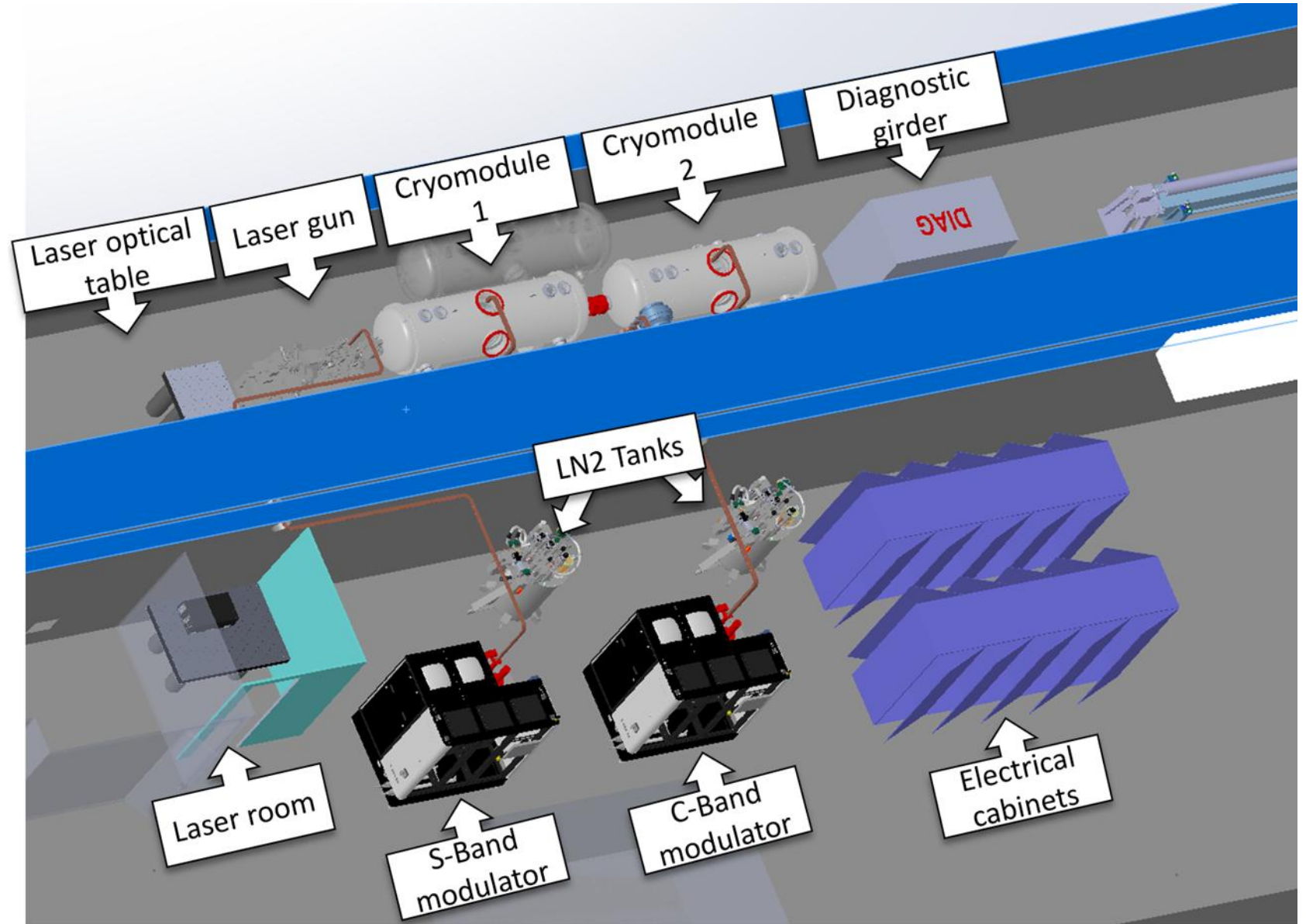
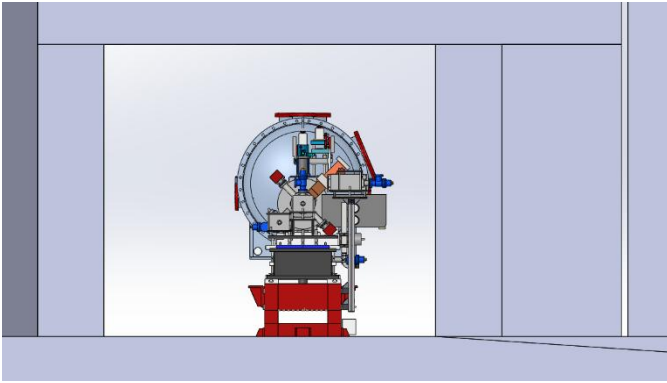

CLEANING & REORGANISATION OF THE MODULATOR HALL AND THE TUNNEL, LOGISTICS



- Linac hall will be reorganized and emptied to allocate the new hardware
- Various storage will be organized in the temporary buildings installed for EBS
- Local crane could be installed if needed

ESRF 10-11-12-13
(200,500,300,700 m²)
Temporary building for:

- storage
- activation measurement

A complex site plan of the ESRF facility. The central feature is the 'Linac' (Linear Accelerator) shown as a curved structure. Surrounding it are various sectors (e.g., SECTOR 01, SECTOR 03, SECTOR 07) and buildings labeled ESRF 1, ESRF 2a, ESRF 2b, ESRF 11, ESRF 12, and ESRF 13. A red circle highlights the ESRF 2a and ESRF 2b buildings. An inset photograph shows two large white temporary storage buildings with gabled roofs, circled in red. Another inset photograph shows a long white industrial building with a gabled roof, also circled in red. Blue arrows point from the site plan to these two photographs.

ESRF2 (2*500 m²) Storage buildings



Modulator hall today



SYRF control room

The Modulator Hall is being reorganized to

- accommodate new electronic racks
- a new control room, modeled on the one of SYRF (MS106), to manage locally both the existing linac and the COLD facility in a more user-friendly area.

- The logistics involves the use of the **Linac tunnel (Pinj) armoured door (20T)**, requiring a dedicated team and specific equipment such as a compressor ensuring safe handling of heavy, radiation-shielded structures integrated with the Personnel Safety System (PSS).
- Equipment handling within the Linac tunnel will utilize **specialized stackers/movers** for ground transport. Specific handling operations could also be done by an external company (like for EBS). Handling equipment will be designed by ESRF mechanical engineering group, built and certified by external companies.
- A dedicated handling area will be created in front of the Modulator Hall building to facilitate movement and temporary storage. The loading dock in front of the Linac will be redesigned, including extension and installation of a canopy/awning that covers the entire building frontage, protecting both the armoured door access and Modulator Hall entry from bad weather.



Movers similar to those used for EBS will be used to move equipment inside the tunnel (No crane).

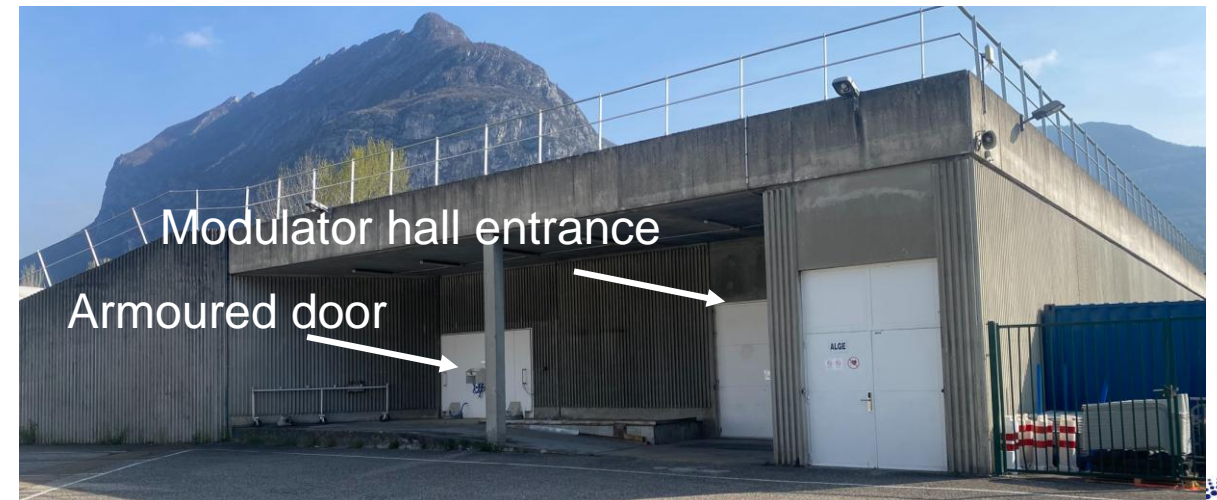

- The electrical distribution in the PINJ building has enough power capacity to supply the new installation. The power supply of the equipment should not require any major modification of the electrical network.
- The electrical network used for the COLD project will be on the "facility network" to avoid impacting USM operation.
- Grounding for the S-band and C-band RF units similar to those installed summer 2025 for Mod3 will be installed.
- Capacity of the air handling unit system to evacuate the heat generated in the PINJ building by the equipment remains to be checked. However, given that most of the calories are evacuated through the water cooling network, the impact on the air handling unit system should be minimal.

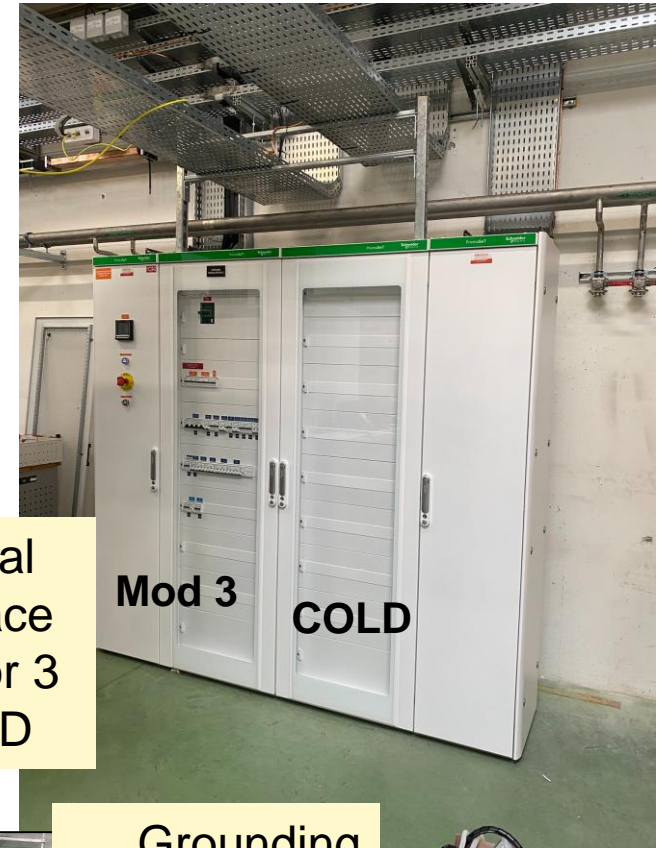

New electrical supply in place for modulator 3 and for COLD



Grounding install for modulator 3

- The main water cooling demands are from the S-band and C-band high power RF-units $\approx 250\text{l/min}$
 → deionized water with properties close to the existing network
- PINJ cooling network can not meet the water cooling needs of the equipment.
- Solution A: a new distribution from the main production
 - Creation of a new SRE distribution from the main pipes in the EXPH to the PINJ building.
 - Pro: existing production station, available spares, available maintenance, reliability ,less expensive
 - Con: Risk of perturbation affecting the operation(quality of water, leak,..), more complicate to install (need shutdowns)
- Solution B: a dedicated water cooling facility for the project
 - Creation of a new SRE production near the PINJ building (chiller, power exchanger, filtering, dedicated instrumentation.
 - Pro: No interaction with the operation system, easier to install
 - Con: Low reliability, need dedicated maintenance and spares, more expensive, cannot be used for phase 3

Solution A has been selected as the most cost effective and with higher potential for future extension terms plans (but not the 6GeV linac).

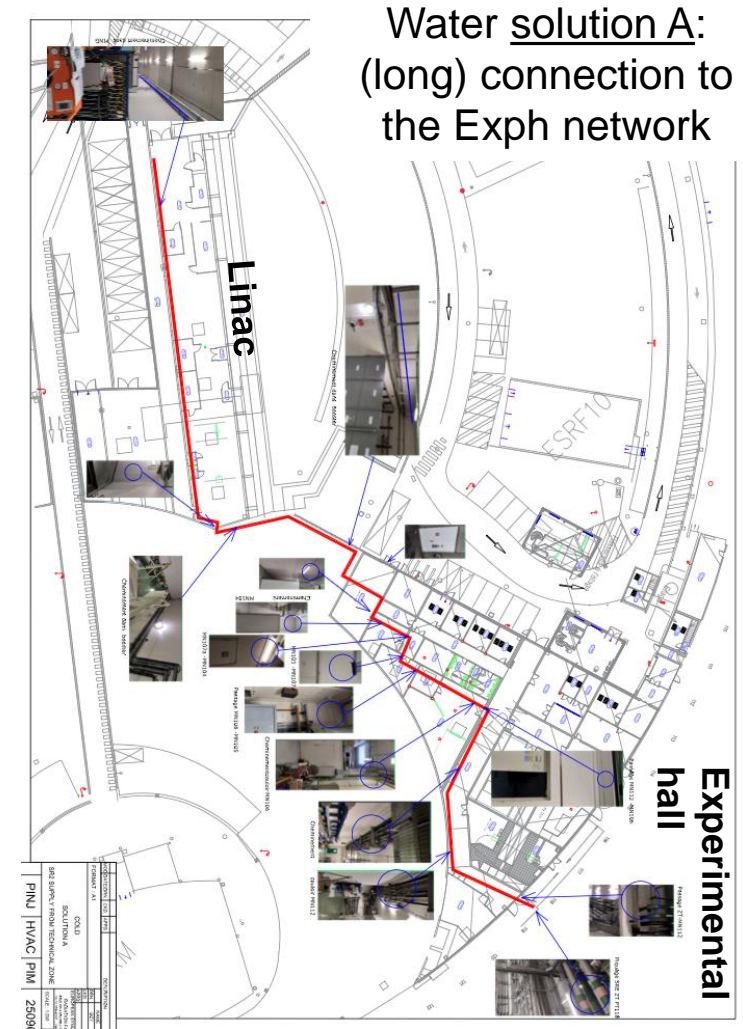

EXISTING ESRF LIQUID NITROGEN NETWORK AND STORAGE

NEARBY LN₂ SUPPLY ~ 110.000 LITERS
(ALREADY USED BY BEAMLINES)

LN₂ NETWORK could BE EXTENDED TO LINAC TUNNEL

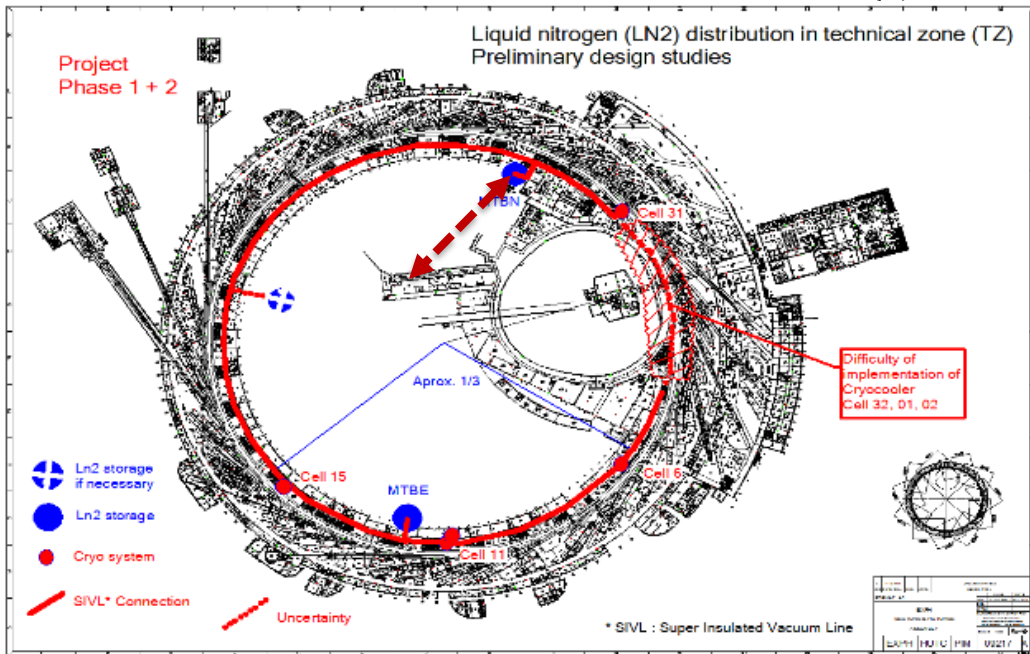
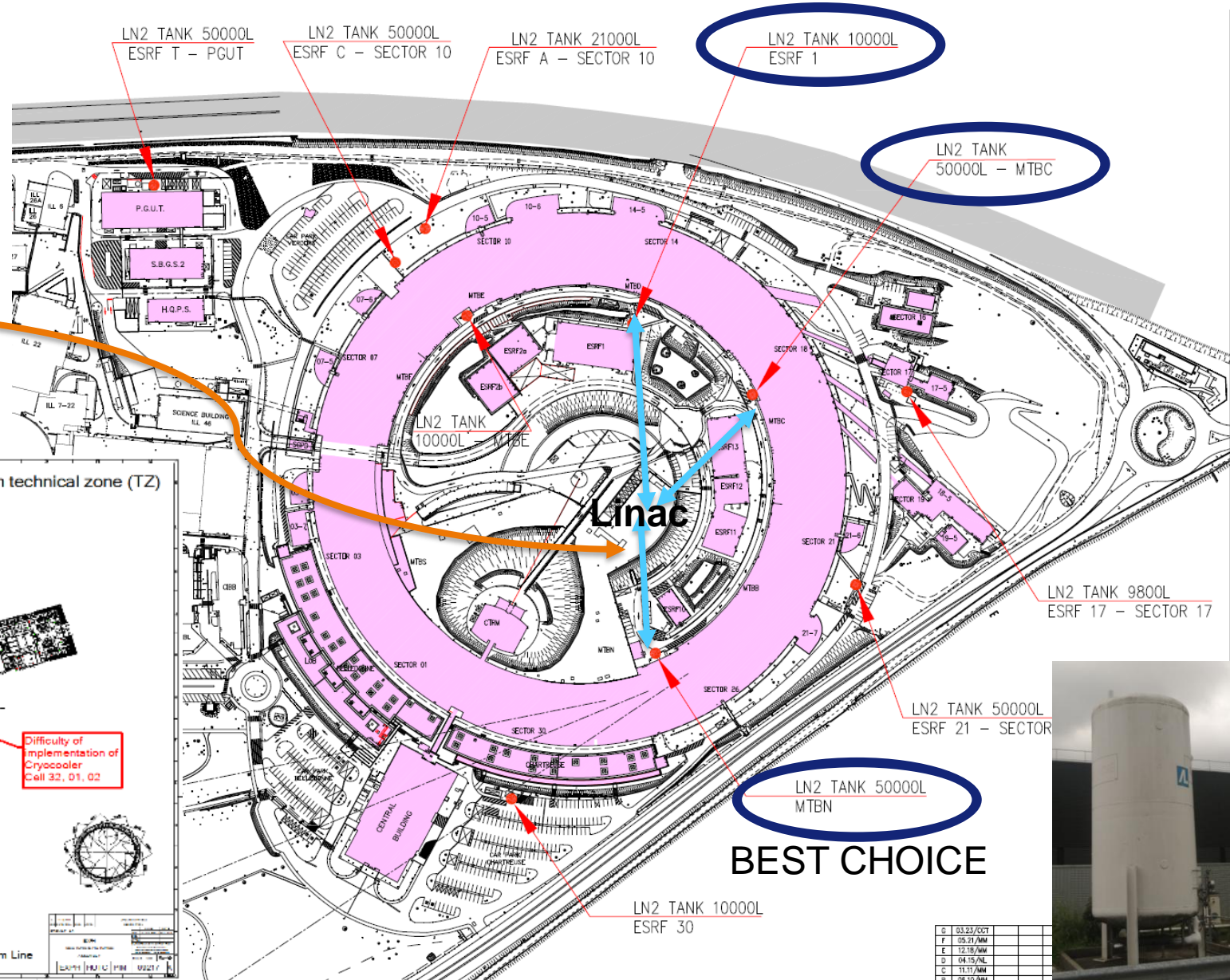

BEST CHOICE



G	03/23/OCT	
F	08/27/AM	
E	12/18/AM	
D	04/15/AL	
C	11/11/AM	
R	06/10/AM	

- The selected technology for the accelerating structures is based on the operation of the accelerating structures at **77K cooled with LN2**.
- Consumption for one cryo-module is 11,2 L/hr, while the maximum LN2 consumption is 33,6 L/hr. The needed cooling capacity depends on the repetition rate and power from RF source (1200 liters for filling SLAC module).
- The highest LN2 consumption will be during conditioning of the accelerating structures, lasting for about 3-6 months. Assuming 24h operation, about 800 L LN2 will be consumed daily by one cryomodule
- The need of a 2000l tank to support automated operation over the weekends with a dedicated LN2 distribution network. The consumption of each cryomodule will be strongly reduced during experimental sessions when a repetition rate of 4Hz and making use of pulse compression.
- The highest LN2 consumption will be during conditioning of the accelerating structures, lasting for at most 3 months. Assuming 24h operation, in the worst case scenario about 800 L LN2 will be consumed daily by one cryomodule.
- For COLD phase 0 and phase 1, **two large capacity (~300 l) dewars** (+ a spare) and existing supply tanks will be used for cost effectiveness and planning for installation
- For COLD phase 2 a closed loop cryo-cooler solution will be studied together with the installation of a dedicated 2000l tank directly connected to cryomodules.



- Due to the presence and manipulation of LN2 in the tunnel and in the modulator hall a dedicated alarm, similar to the protection installed on the beamline, must be implemented.
- This system is based on a detection and a strong extraction unit.
- Technical services will launch a study to define and built the system
- Alarm reported also in the control room
- Validation by the safety group



INTERLOCK: PERSONAL SAFETY SYSTEM

The Linac tunnel is accessible during USM/MDT
If LB1 and LB2 are in control access

The Linac tunnel can be operated during Shutdown
If LB1 and LB2 are close and a special key mode is activated

Same logic is used for the present linac and for COLD

A special control access mode, similar to those installed on some beamlines, will be added to be able to work in the tunnel on the tuning of the laser (class 4) of the gun.

New: Dedicated Gamma monitors are in booster zone and kill SR beam in case of excessive dose.

A fence door (installed and in operation) inhibits the detectors if the intervention in controlled access take place in the first part of the linac tunnel

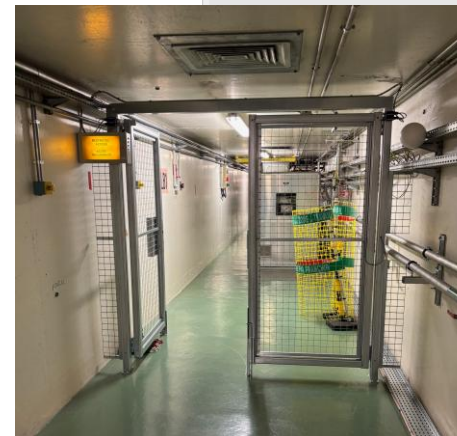
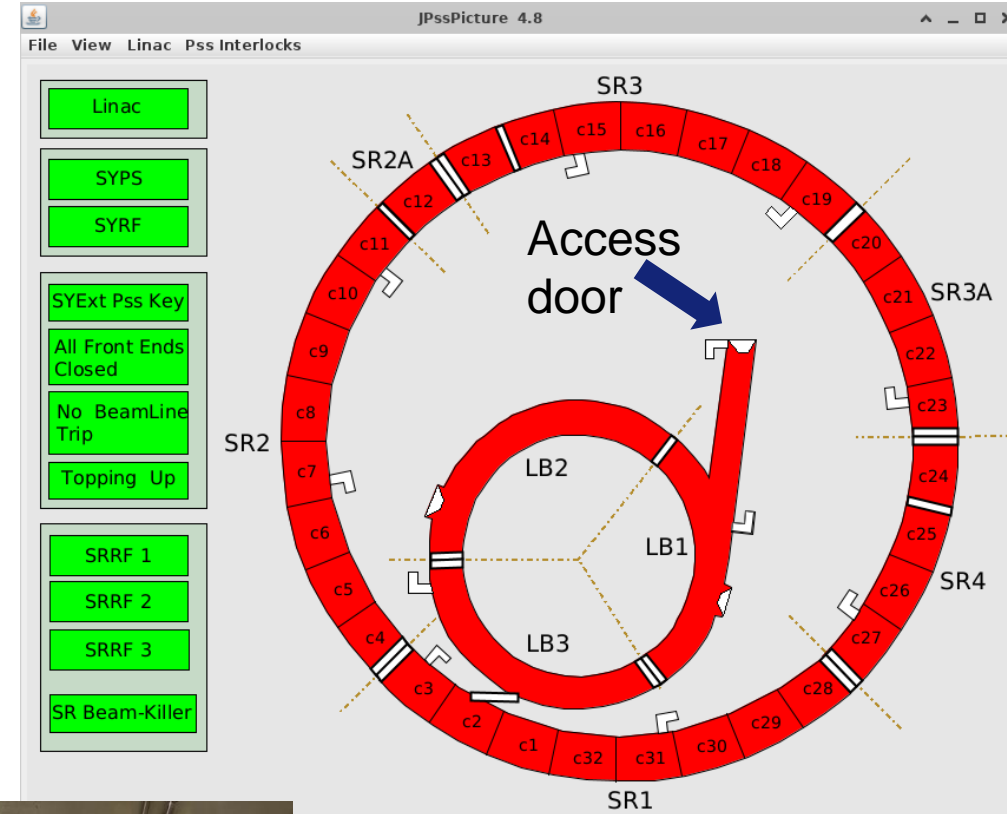

INTERLOCK: EQUIPMENT PROTECTION

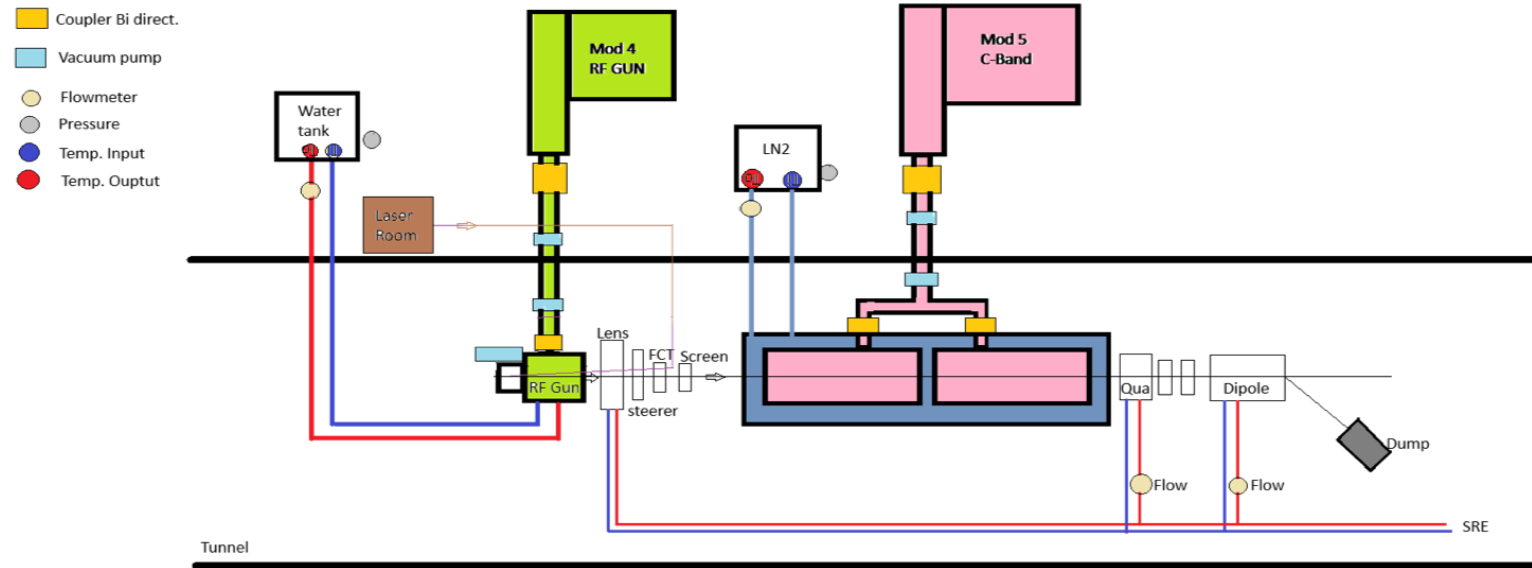

The sections and modulators will be protected using a system similar to the present linac or to the RF system of the storage ring: managing RF, Vacuum, Flow, temperature protection.

- There is no interaction with the equipment used for operation for phase 0,1,2
- The machine interlock system could be extended for phase 3

The infrastructure protection system (water leak detection, fire alarms,...) will be extended to COLD area

COLD control system will largely benefit from the present linac system and from its refurbishment.

- Using similar hardware will drastically reduce the software development because existing Tango device servers could be reused or adapted.
- Control for the Scandinova modulators has already been developed for the linac refurbishment
- An independent Tango-Controls HDB++ database instance will be installed to store the data related to the COLD linac project

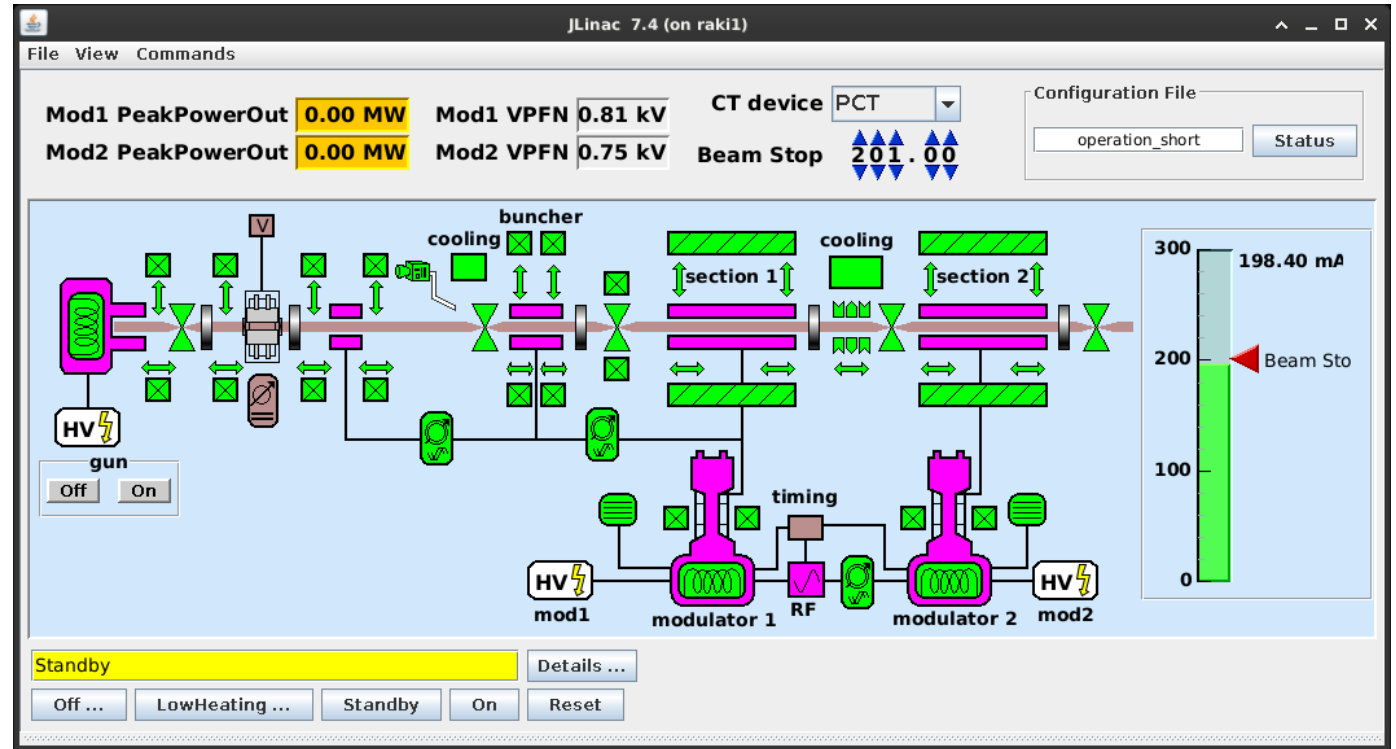

- A Graphical User Interface (GUI) application similar to the current Linac application will be developed to easily access an overview of the system and control the COLD linac locally and from the control room.
- Another GUI application will be developed for the waveguides control and monitoring display the powers and pressures in different parts of the system.
- We could consider the preparation of a digital twin based on RF-Track simulations as the one of the EBS-SR to start creation of Device Servers and applications for control of COLD.

OPERATION: COLD OPERATING CONDITIONS WITH SR OPERATION:

- COLD facility will operate in close **coordination with the operation** of the Storage Ring and of the Injector, with scheduling protocols.
 - **During USM** (User Service Mode) times, COLD can operate independently of the injector and the storage ring. Hourly access in the tunnel for interventions during 45 minutes can be organized between SR top-up refills, with the option to prioritize COLD activities by skipping SR refills if needed.
 - **During MDT** (Machine Dedicated Time), COLD can also be operated. Access for intervention in the tunnel may be limited based on Linac availability and use for injection in the storage ring. Dedicating MDT to COLD can also be planned.
 - **During shutdown** periods, the tunnel will be open for installation activities and tests. The specific booster tunnel sections LB1 and LB2 could be closed to support COLD operation.
- COLD control system will allow a full remote access using an application similar to the existing Linac which can be used from the main control room. The **Control room Operators** team will be trained for both COLD conditioning and run tests, ensuring oversight and a streamlined operational process.
- The hardware and control system of COLD phase 0, 1, 2 will be fully independent of the existing facility. It should not interfere with the operation of the storage ring and should not produce beam failure or affect the beam quality and user service.

During phase 3, COLD will replace the existing Linac to inject in the Booster. This phase is essential and will only start after a complete **evaluation of the operability of the system**.

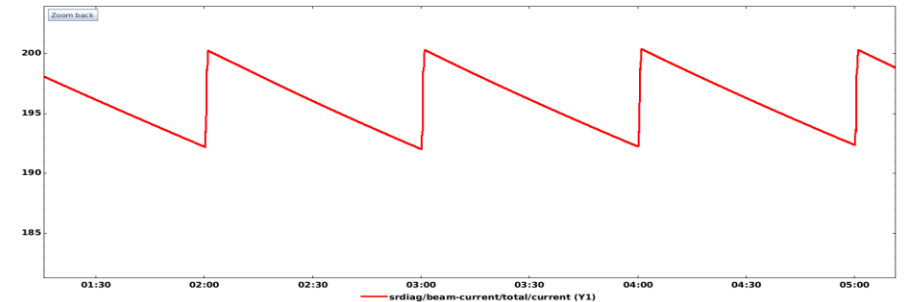

- Phase 0, 1, and 2 will demonstrate beam and equipment performance, while phase 3 will demonstrate the operational performance required for a user facility.
- The project could start with minimal investment, but by the end of Phase 2, the reliability, the maintainability and the repeatability of the equipment must be fully assessed to be better or equivalent to the present injector facility.
- In 2025, over 5362 top up refills, 129 (2.4%) did not take place due to failures of the injector. This gives an overall reliability of 98.6% for the whole injector, equally distributed between the linac, the booster power supply, the booster RF and the injection/extraction elements.
- In the case a full-energy Linac is approved, it will be designed with margin in energy (one RF unit, 300MeV) and RF power equivalent to a full module. The operation with a defective cryomodule or a faulty RF station should also be validated during COLD project Phase 1 to 3.
- A critical element will be the laser gun system, which should require a hot spare.
- The new linac will replace the present injector (except for the injection/extraction system in the SR). Ideally, the overall reliability should be in the order of 98%, with a mean failure duration in the order of 1 hour including the **cryogenic system**.

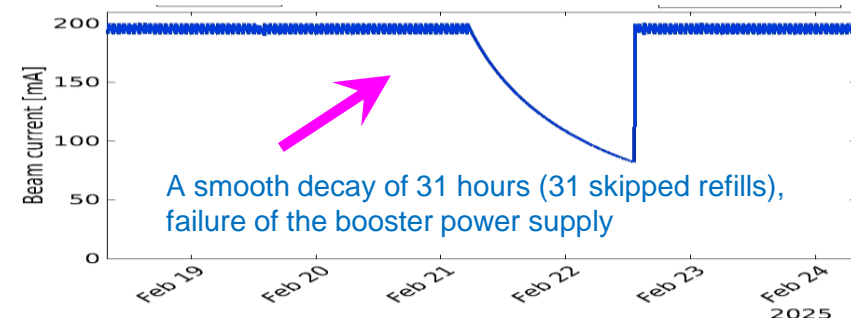
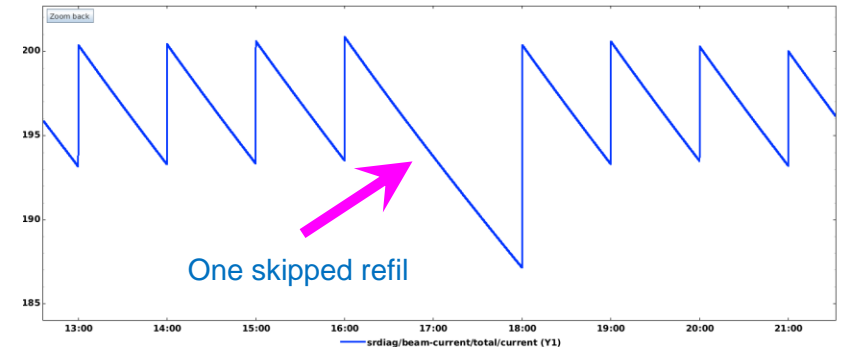

The procedure to obtain L'*Autorité de sûreté nucléaire et de radioprotection (ASNR)* approval requires drawings, simulations and a CDR document.

~2 years to obtain permission for beam. We are on schedule and have started preparing the documentation.

6GeV Linac Injectors upgrade project is the ultimate justification for ASNR to approve the COLD project

ASNR approval process: Prepare → 6 months → Submit → 1 year → Obtain (accelerators)
Submit → 6 months (or less) → Obtain (klystrons)

Deadlines:

COLD authorization will partly benefit from the work done to prepare Linac Refurbishment authorization.

COLD authorization preparation starts right after Linac refurbishment authorization

Only declarations are needed for Xray sources like klystron

Max declared energy for COLD 350 MeV

1 st Dec 2025:	Prepare Drawings and beam information for Linac refurbishment (DONE)	
	Submit authorization for S-band RF unit (Klystron) (DONE)	
1 st July 2026:	Submit authorization request to use RI structure as spare for section 1 or2 (spare section not identical to present one) (ready for submission)	
	Obtain authorization for S-BAND RF units (klystron) (Done)	
1 st July 2027 :	Obtain Authorization for present linac to use the spare section	Linac Refurbishment
2 nd July 2026:	Prepare Drawings and beam information for Phase 1-2-3-... (In progress) <small>Linac parameters 1000 part 6D beam at linac end</small>	Cold
	Submit authorization for C-band RF unit (Klystron) Phase 0	
1 st Oct. 2026:	Submit authorization request for Phase 1-2-3 (Start in a few week)	
	Obtain Authorization for C-band RF unit Phase 0	
1 st July. 2028:	Objective for Authorization for beam 1-2-3-...	
1 st Jan. 2028 :	Obtain Authorization for beam <u>Phase 1-2-3-...</u> (if second round needed)	

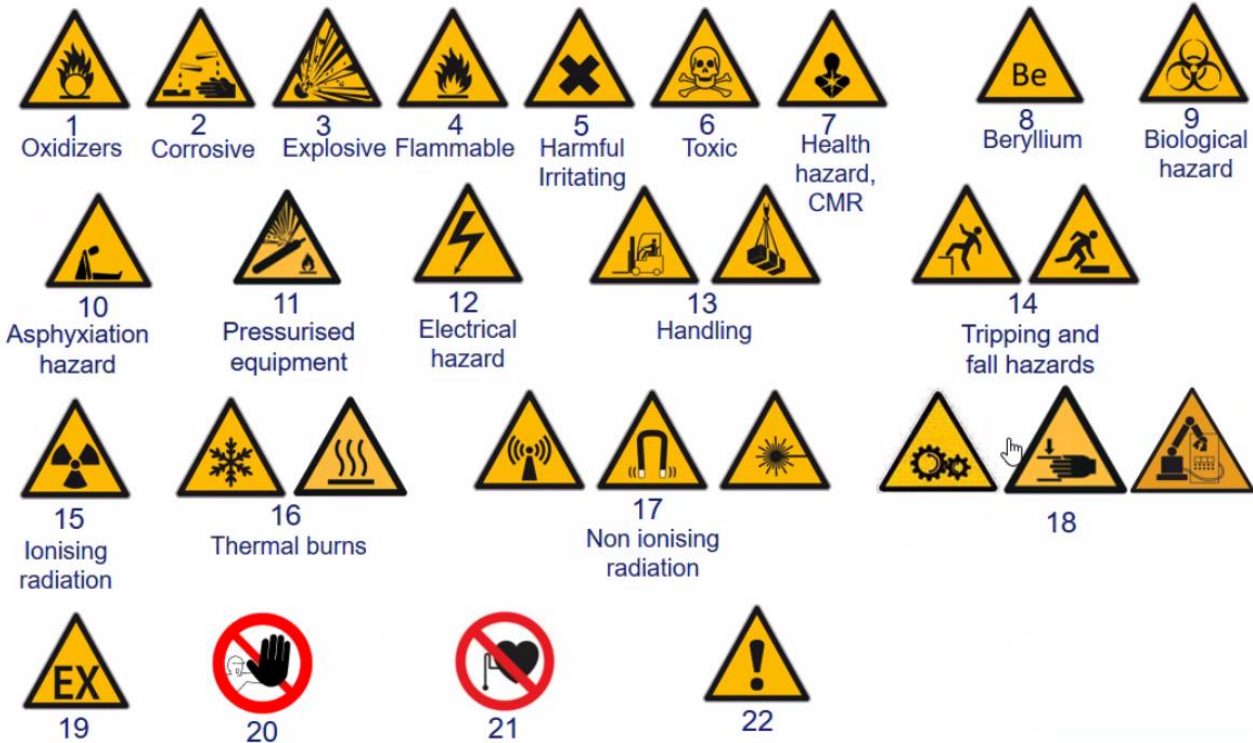

Safety is the first priority.

This project is complicated and realized in an operational environment. All type of risks are present.

ESRF already has all procedures in place.

With EBS and the ongoing projects, the project team have all the expertise to run the COLD project in a professional manner.

Phase 1 (blue): Construction of a new building in parallel to the existing Linac

- Adaptation of the existing buildings and infrastructure
- Construction of the tunnel and hall should be compatible with /adapted to user operation (mostly shutdown, impacting operation planning)

Phase 2 (Green): Installation and commissioning of the Linac

- Independent of the user operation

Phase 3 (Red): Construction of the transfer line and connection to the storage ring

- Could we built it on top of the existing booster?
- Need a longer shutdown

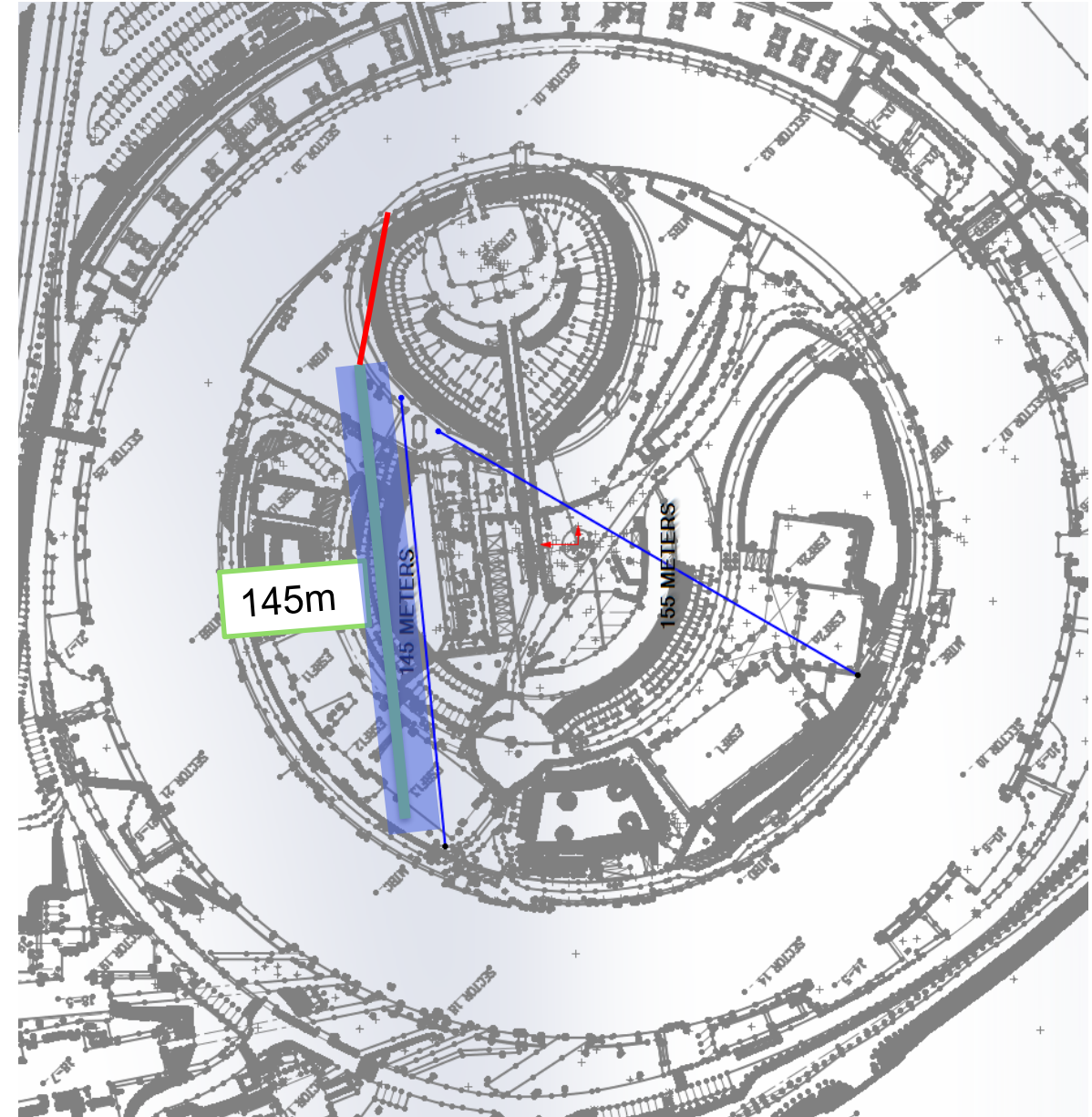

- Linac refurbishment is essential for medium term reliability of the facility
- Linac refurbishment is in progress and will benefit to the implementation of COLD project
- Installation of COLD can only start after the RF conditioning of the spare cavity

- COLD project is essential for medium & long term reliability and performance of the facility
- COLD is primarily a demonstrator
- The infrastructure is adapted to the need and will require minimum adaptation (LN2 and water cooling being the largest required)
- Beam authorisation preparation is on going and should be obtained on time
- COLD project is compatible with ESRF user operation

- COLD project is an exiting project for the next years and for the junior generation
- Human resources to realize and support the project is the critical issue

MANY THANKS FOR YOUR ATTENTION

S.Liuzzo on behalf of the COLD project team:

A.D'Elia, P.Borowiec, V.Serriere, M.Dubrulle, M.Morati, S.White, F. Ewald, N.Benoist, K.Scheidt, B.Roche, C.Benabderrahmane, G. Le Bec, R. Bourtembourg, J.-L. Pons, D. Martin, C. Gonzalez Torres, B. Pelissier, L.Eybert, T.Brochard, C.Maccarrone, J.-L. Revol, B.Joly, Y.Gouez, H. Pedroso Marques, P.Colomp, A.Dely, F.Falaise, David Frichet, D.Flood, A.Talucci, P.Lean, A.Dely, Q.Qin
International collaborators
E.Nanni, A.Dhar, W.-H. Tan, G.Aymar (SLAC),
A.Latina (CERN),
D.Alesini, F.Cardelli, A.Giribono, C.Vaccarezza, G.Silvi (INFN-LNF),
M.Andorf, J.Maxson (Cornell),
P.Craievich, R.Zennaro (PSI)
P Berkvens (Consultant)

Special thanks to ESRF management and other divisions, for their support to the COLD project

6GeV Linac injector