

The SUNDAE2 measurement system at European XFEL



Thomas Schmidt, Michael Ronniger

thomas.schmidt@xfel.eu
michael.ronniger@xfel.eu

ID26, Deauville, May 16-17



Outline

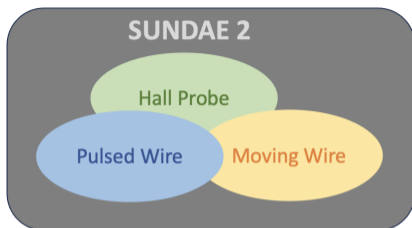

Setup:

- Pulsed Wire Method
- Experimental Setup
 - Overview
 - Vacuum Chambers
 - Stages
 - Current Pulse Sources
- Laser Cube

Measurements:

- Laser / Scope Evaluations
- Sensitivity Tests
- Arbitrary current pulses
- Signal decay
- Beat Oscillations
- Wire Calibration
- 1st Field Integral under Vacuum

Pulsed Wire Method

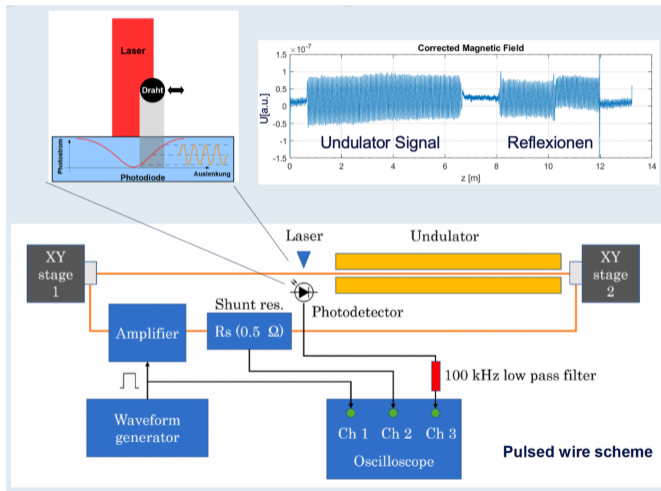

- electrical pulse in a thin wire
- wire stretched to yield point
- current deflects wire in magnetic field
- wave propagates in both direction
- measurement completed before reflections

Experimental Setup - Overview

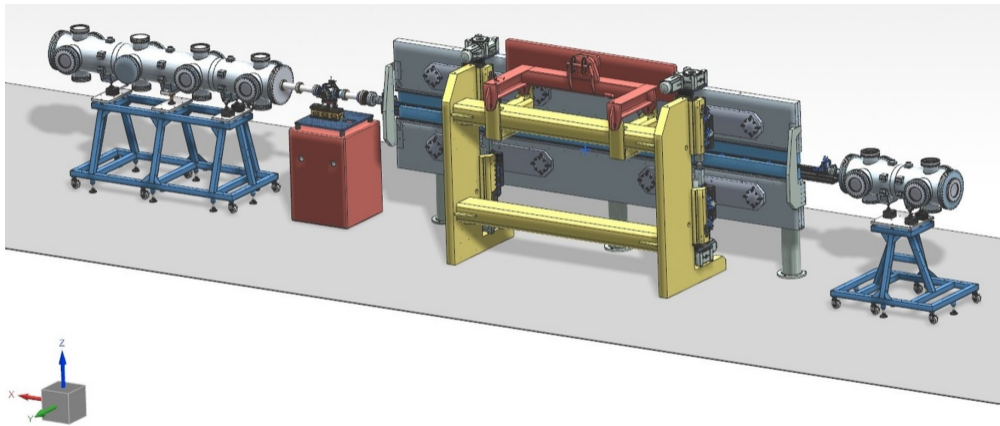

Experimental Setup: Overview



Experimental Setup: Vacuum chambers

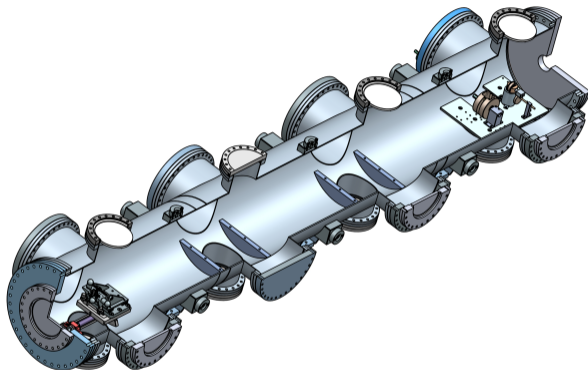

- Special Vacuum chambers produced by CECOM.
- Vacuum System following UHV rules

Experimental Setup: Stages

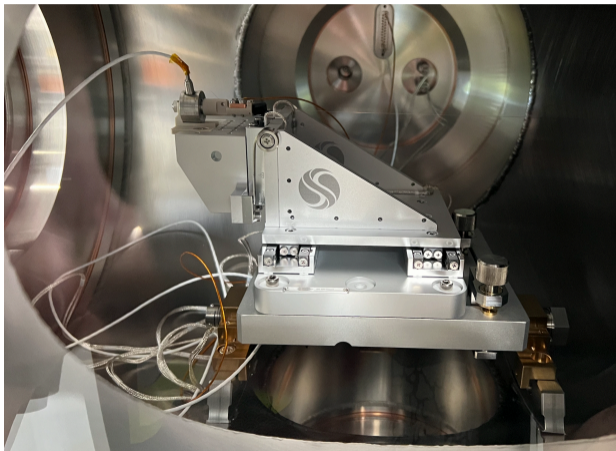

- xy piezo stages (SmarAct)
 - pulsed wire
 - moving wire
 - 60mm / 25mm travel
- z Phytron stepper
 - in situ tensioning
 - 150mm travel
- Tension sensor (Burster)
- Sorbothane damping

Experimental Setup: Stages

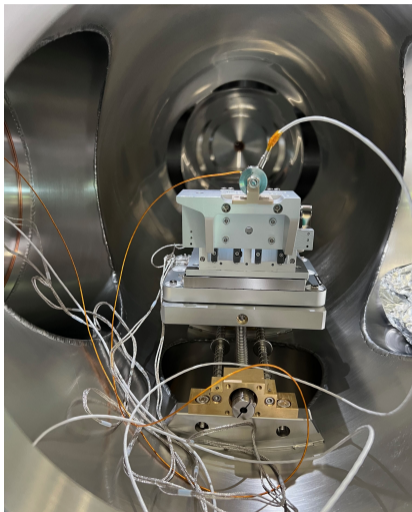

- xy piezo stages (SmarAct)
 - pulsed wire
 - moving wire
 - 60mm / 25mm travel
- z Phytron stepper
 - in situ tensioning
 - 150mm travel
- Tension sensor (Burster)
- Sorbothane damping

Current Pulse Sources

- control unit
 - bipolar pulser GBS burstpuls1000
 - switch for direct / Diodes / MosFET
 - switch for Shuntss $1\Omega - 330\Omega$
- AETechron 7234
 - up to 150V
 - bandwidth 100kHz
- Hubert A1230-2
 - $2 \times 75V$
 - bandwidth 1MHz
- Hubert Transformer
 - factor 3
 - short pulses only

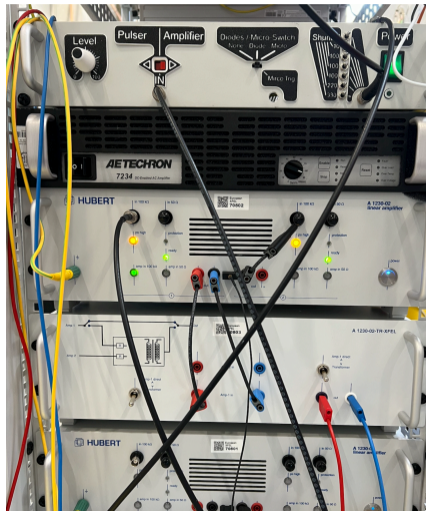

Laser Cube

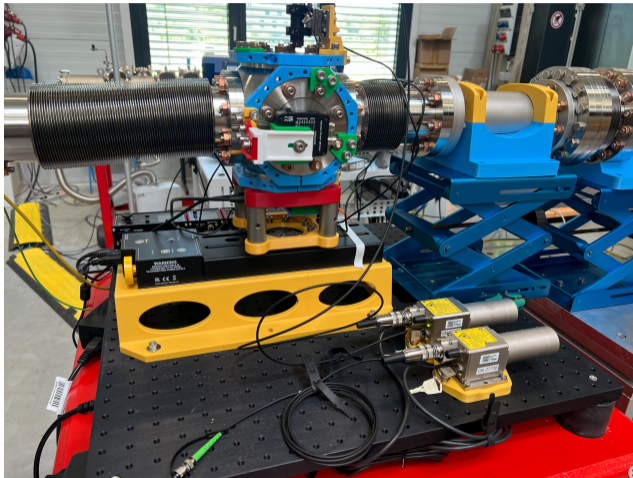

- wire oscillation detection
 - in both planes xy
 - longitudinal positioning
- Laser S+K nano51-S
 - fiber coupled diode
 - low noise
 - adjustable power
 - 0.5W - class 2
- Photodiodes Thoarlabs
 - adjustable gain
 - low noise

Laser Evaluation

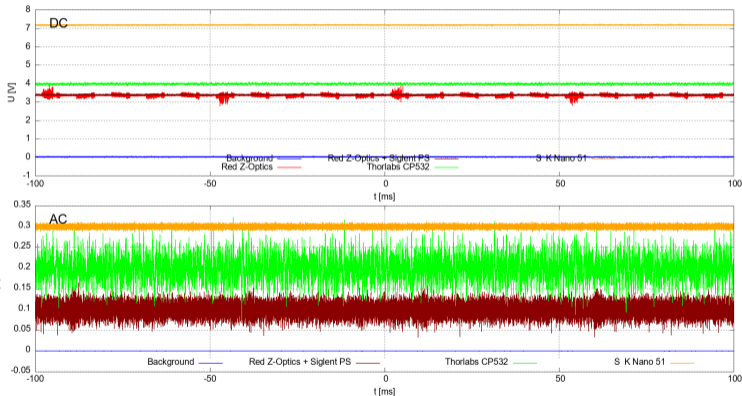

■ Laser / Photodiode noise

■ DC

■ AC

■ Test field

■ Thorlabs (green)

■ Z-laser (red / brown)

■ **Schäfer + Kirchhoff**
(orange)

■ Photodiode

■ **Thorlabs** (blue)

■ adjustable gain

Oscilloscope Evaluation

constant signal

signal splitted

same signal 4all

Oscilloscopes 12bit ADC

LeCroy

Pico HD "16bit"

Rhode & Schwarz HD
"18bit"

HD modes

lower noise

sacrificing bandwidth

Pulsed Wire

pulse 1 - $25\mu\text{s}$

signal 5 - 50 kHz

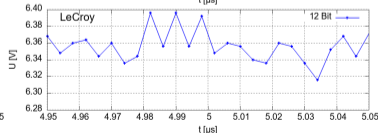
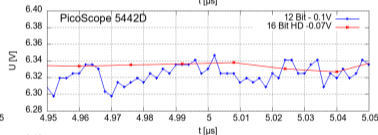
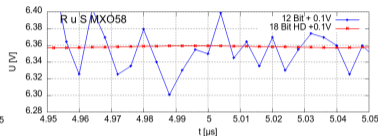
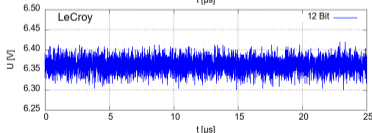
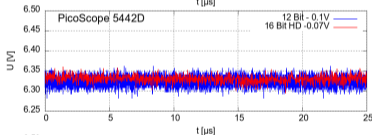
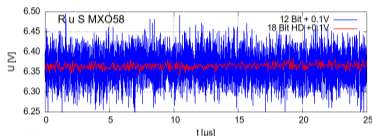

Sensitivity Tests in first and second field integrals

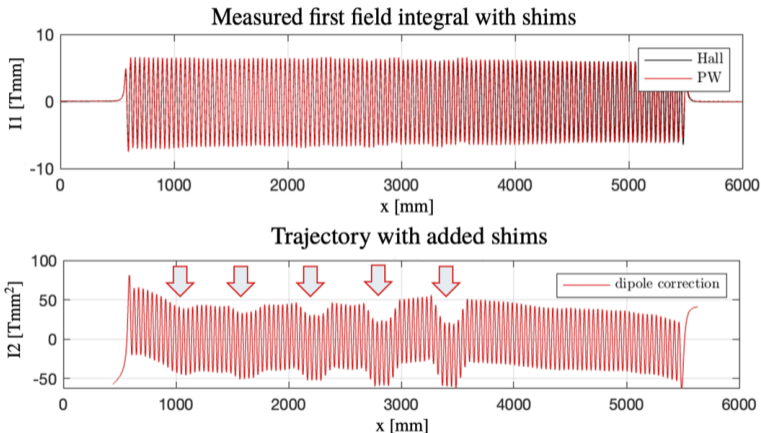

shim thickness $50\mu m$, $100\mu m$, $200\mu m$, $300\mu m$, $400\mu m$

Pulse Forms: new approach

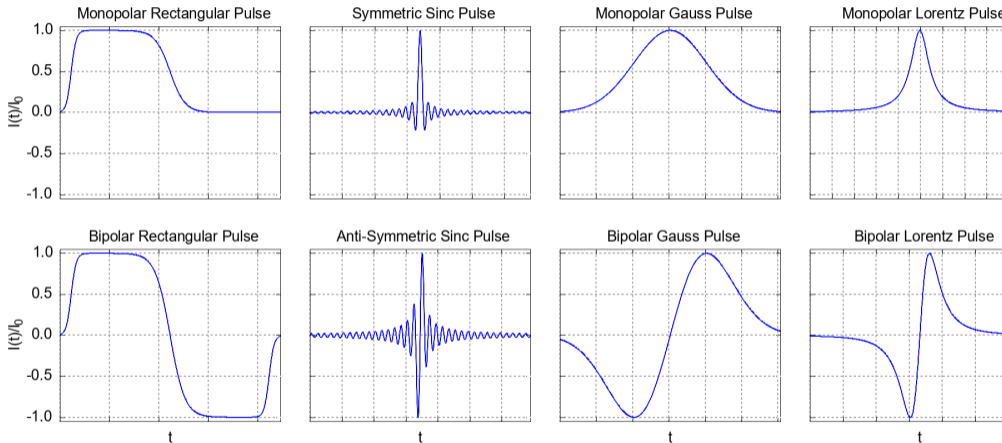

Decay

Observation:

- strong decay
- Diodes reduce decay strongly
- decay not visible anymore in vacuum

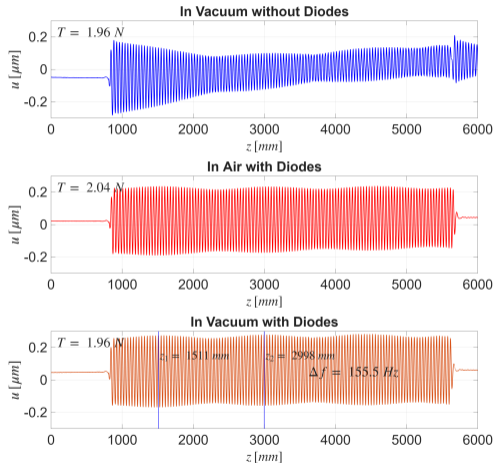
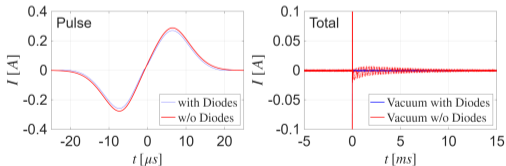

Beat Oscillations

Observation:

- low frequency oscillation
- matches longitudinal waves

$$c_T = \sqrt{\frac{T}{A\rho}} \approx 231 \frac{\text{m}}{\text{s}}, \quad c_L = \sqrt{\frac{E}{\rho}} \approx 3881 \frac{\text{m}}{\text{s}}$$

$$f_T^{(n)} = \frac{nc_T}{2L} \approx n \times 10 \text{ Hz}, \quad f_L^{(n)} = \frac{nc_L}{2L} \approx n \times 173 \text{ Hz}$$

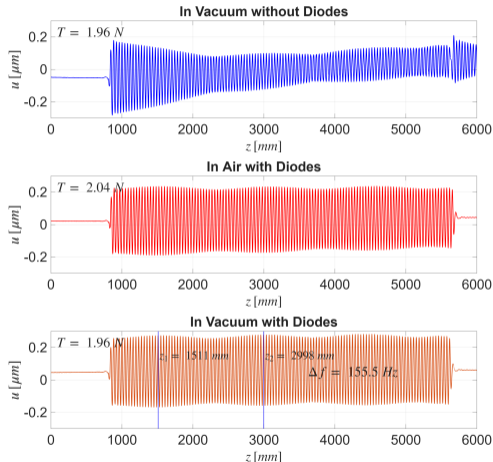
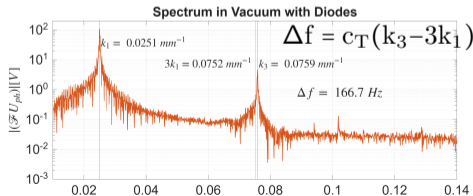

1st Field Integral under Vacuum

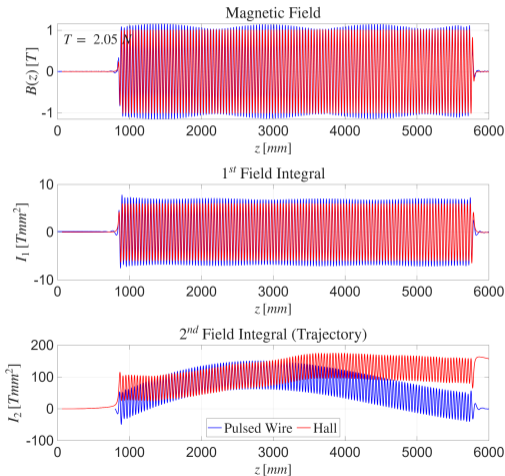

- Pulsed Wire (blue)
 - rectangular pulse
 - 10 μ s pulse width
 - 75 μ m CuBe wire, 200cN
 - 32 averages with individual calib
 - no earth field compensation
- Hall probe data (red)
- no decay, only beating
- no corrections applied
- pretty good agreement

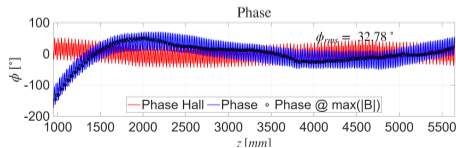

Wire Calibration

- Position data can be obtained from:
 - an internal or external position sensor
 - the stage movement speed
- Smooth spline: photo voltage vs deflection

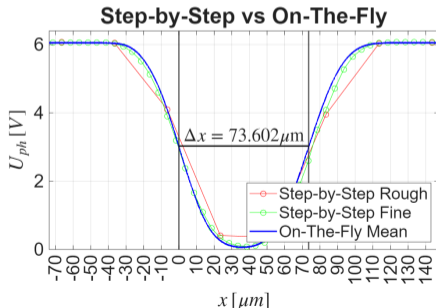

- Continuous calibration monitoring (long pulsed-wire measurements)
- On-The-Fly measurements \Rightarrow short measurement times
- On-The-Fly: position voltage encoding

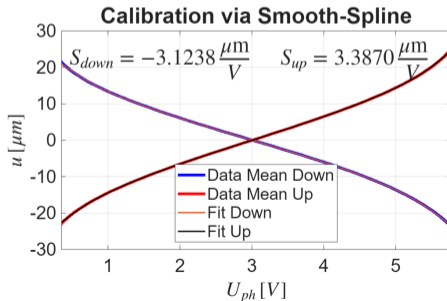

Summary

- SUNDAE2 setup optimized and tested for 5 m SCUs
- Vacuum operation successfully started
- Pulsed-wire data quality significantly improved
- Feedback current eliminated
- Remaining signal loss attributed to air resistance
- Beat oscillations still present, likely caused by longitudinal oscillations
- Beat oscillations affect:
 - field integral measurements
 - phase error analysis
- Undulator trajectory successfully reconstructed under vacuum
- System ready for trajectory measurements on SCU modules

Outlook

- include 2nd laser line
- include Hall Probe and Moving Wire
- suppress or correct beat oscillations
- extend software for arbitrary pulse shapes
- Correction algorithms and systematic effect compensation under development
- Hall probe system: currently being assembled and prepared for combined testing
- Full operational readiness planned by end of 2026



MAGNETIC DISCUSSION

Bruno Rommel

Thank you for your attention!

and all Undulator System Group members, especially

Enrico Fioresi

Suren Arbeghyan

Amir Doosti

Jacques Abendhaim

Uwe Englisch

Sara Casalbuoni

and

Raul Villanueva (Vacuum), Torsten Wohlenberg, Lukas Müller (DESY)