



University of Science and Technology of China  
National Synchrotron Radiation Laboratory

# ID developments at University of Science and Technology of China (USTC)

*Zhouyu Zhao | May 15<sup>th</sup>, 2026*

On behalf of  
HALF ID group

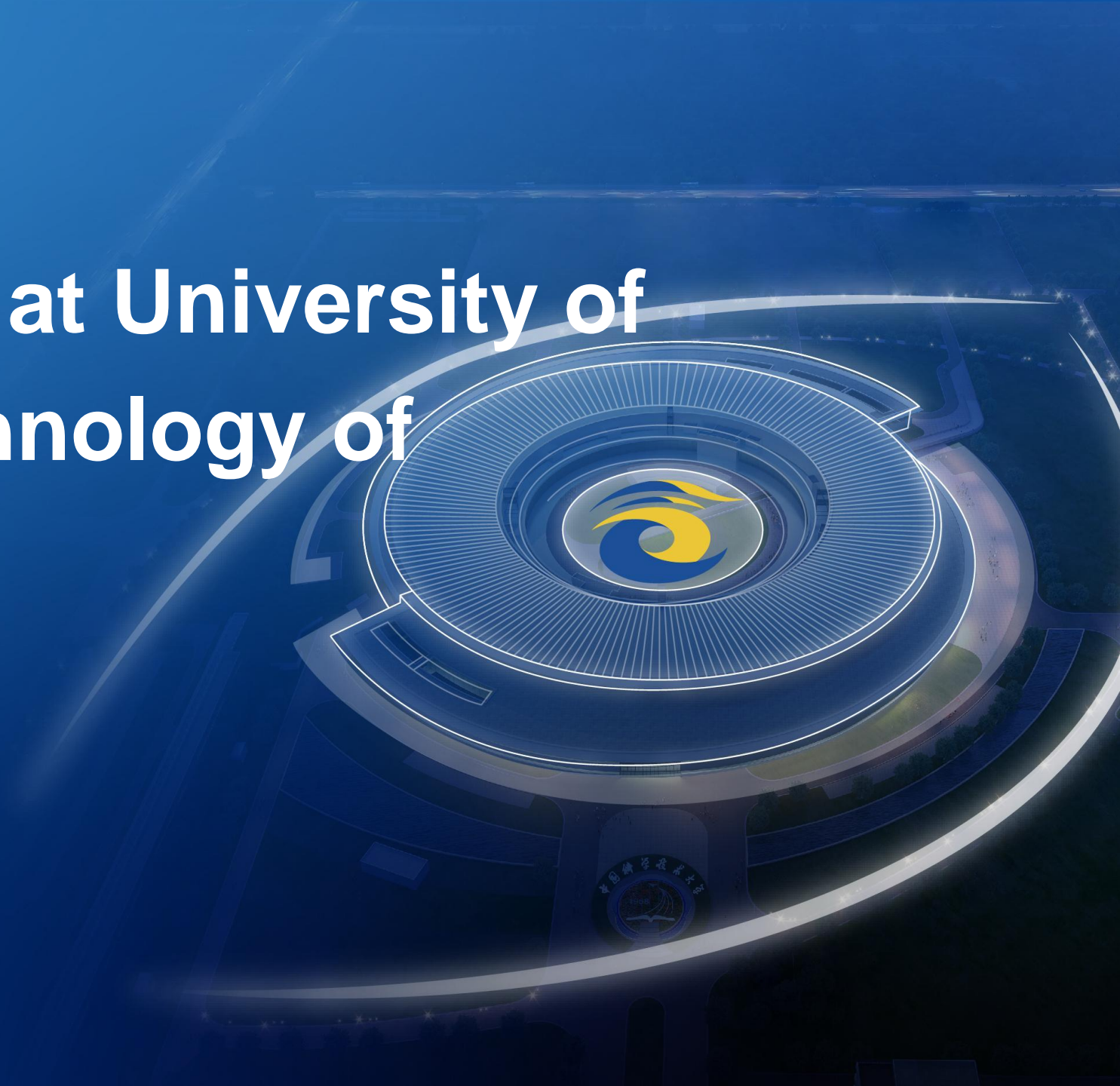

# OUTLINE

**01 Overview of Insertion Devices at USTC**

**02 ID commissioning for HALF**

**03 Future perspectives**

**04 Summary**

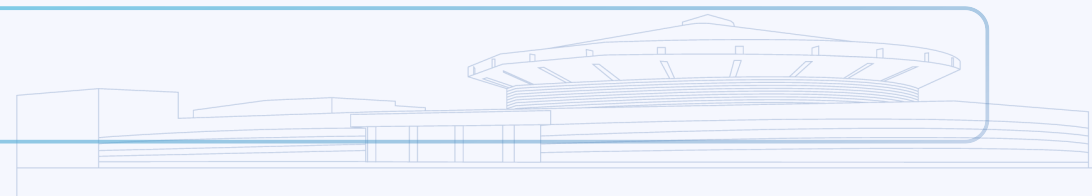

# Overview of SR developments at USTC

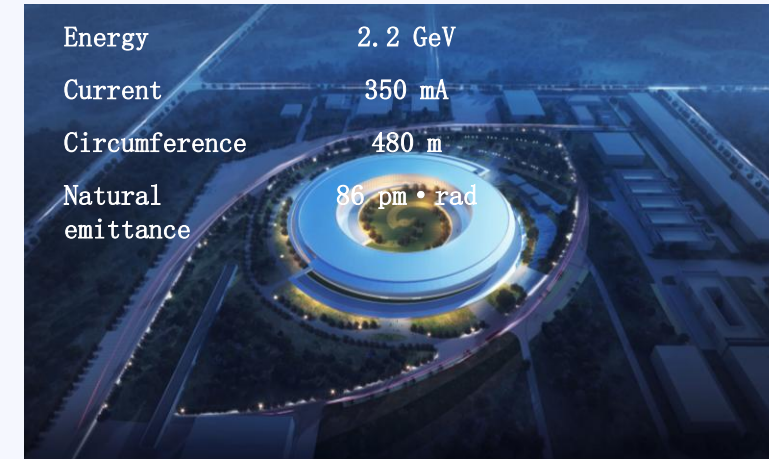
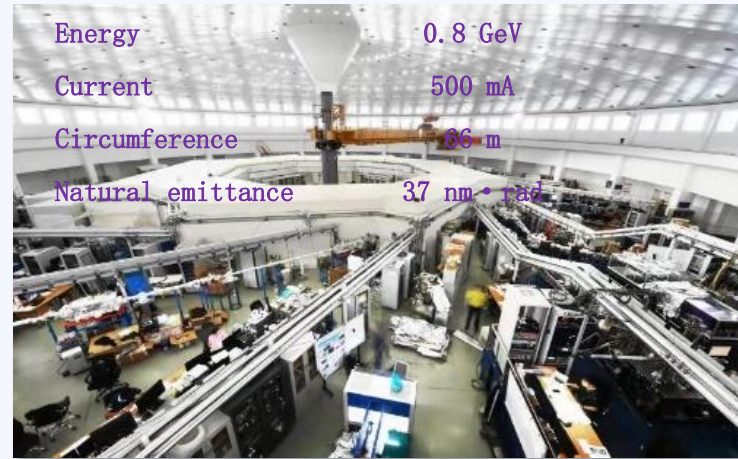

**HLS**

**Born in 1991**

**HLS-II**

**Upgraded in 2014**

**FELiChEM**

**2022**

**HALF**

**New in 2028**

**USTC has the first National Laboratory in China (1983):**

- Hefei Light Source (**HLS**) is the first dedicated synchrotron radiation light source in China;
- FELiChEM is the infrared FEL user device in China;
- Hefei Advanced Light Facility (**HALF**) is China's **first** low-energy 4<sup>th</sup>-generation SR light source (under construction, planned completion in 2028).

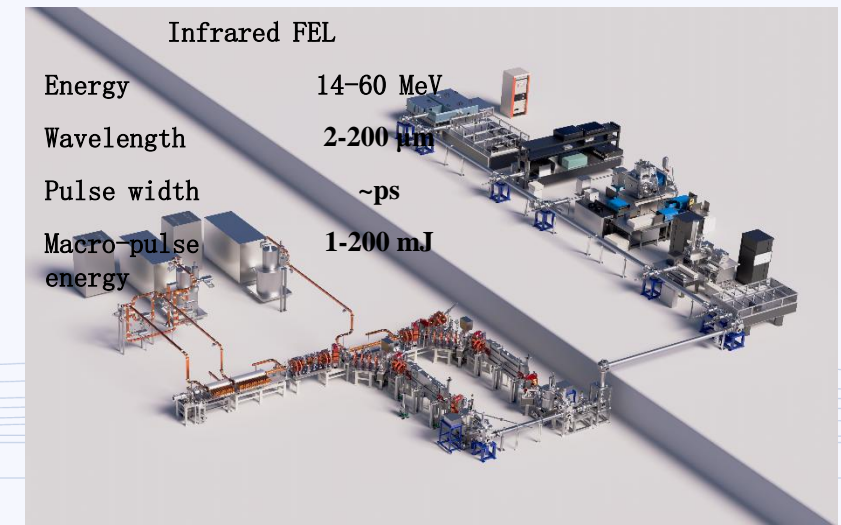

Type	EPU	LPU	EPU	IVU	WIG	QPU
Period length	50 mm	92 mm	104 mm	40 mm	156 mm	88 mm
Period number	58	29	31	30	10	18
Peak field	0.37 T	0.46 T	0.65 T	1.01 T	1.22 T	0.62 T

Type	LPU	LPU
Period length	46 mm	56 mm
Period number	50	40
Peak field	0.75 T	0.63 T

**IDs at HLS-II** (*Manufactured by Chinese companies and KYMA*)



**First SR ID (LPU92) in China** (*Developed by USTC*)

**IDs at FELiChEM** (*Manufactured by KYMA*)

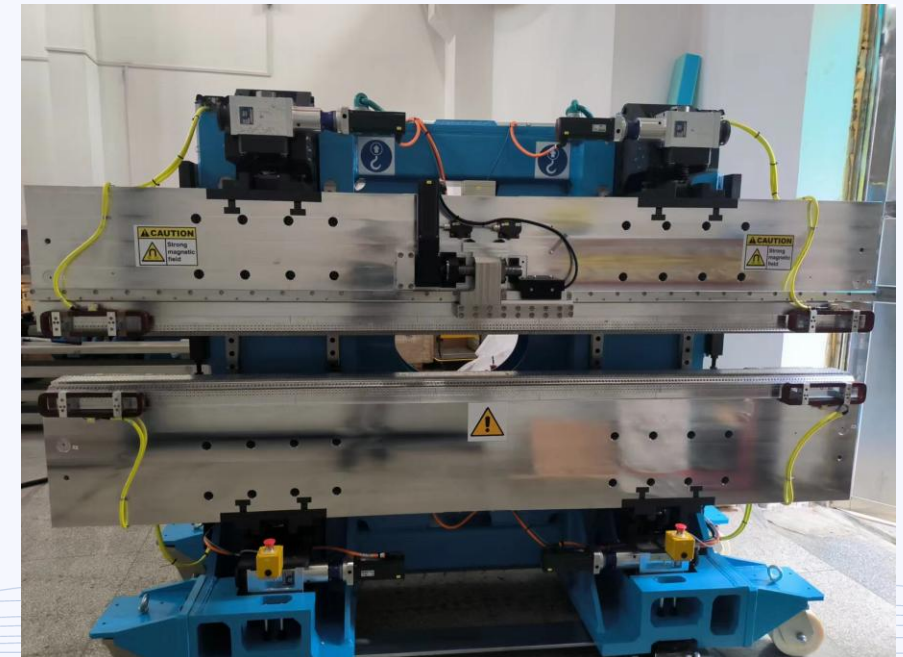

**EPU50** (*Manufactured by KYMA*)

- HALF is a brand-new 4<sup>th</sup>-generation SR light source in China, **approved in 2022** with a budget of **¥ 2.8 billion RMB** (~\$ 400 million USD).



## Parameters of HALF

Electron energy	2.2 GeV
Average current	350 mA
Circumference	480 m
Natural emittance	86 pm rad
Number of long straight (LS) section	20
Number of middle straight (MS) section	20
Length of LS/MS section	5.3 m/2.2 m
Minimum gap of out-vacuum ID	12 mm
Minimum gap of in-vacuum ID	6 mm
Beta function (x/y) at LS	6.8/2.5 m
Beta function (x/y) at MS	2.5/1.9 m
Dispersion function at LS/MS	0.0005/0.03 m

- Installation of injector and storage ring are in progress.
- Construction period: ~**64 months** (Mar. 2023 - July 2028).

- Phase I (2023-2028): 11 beam lines (10@LS 1@MS) under construction (15 IDs).
- Phase II: ~20 beam lines to be constructed (20-30 IDs).

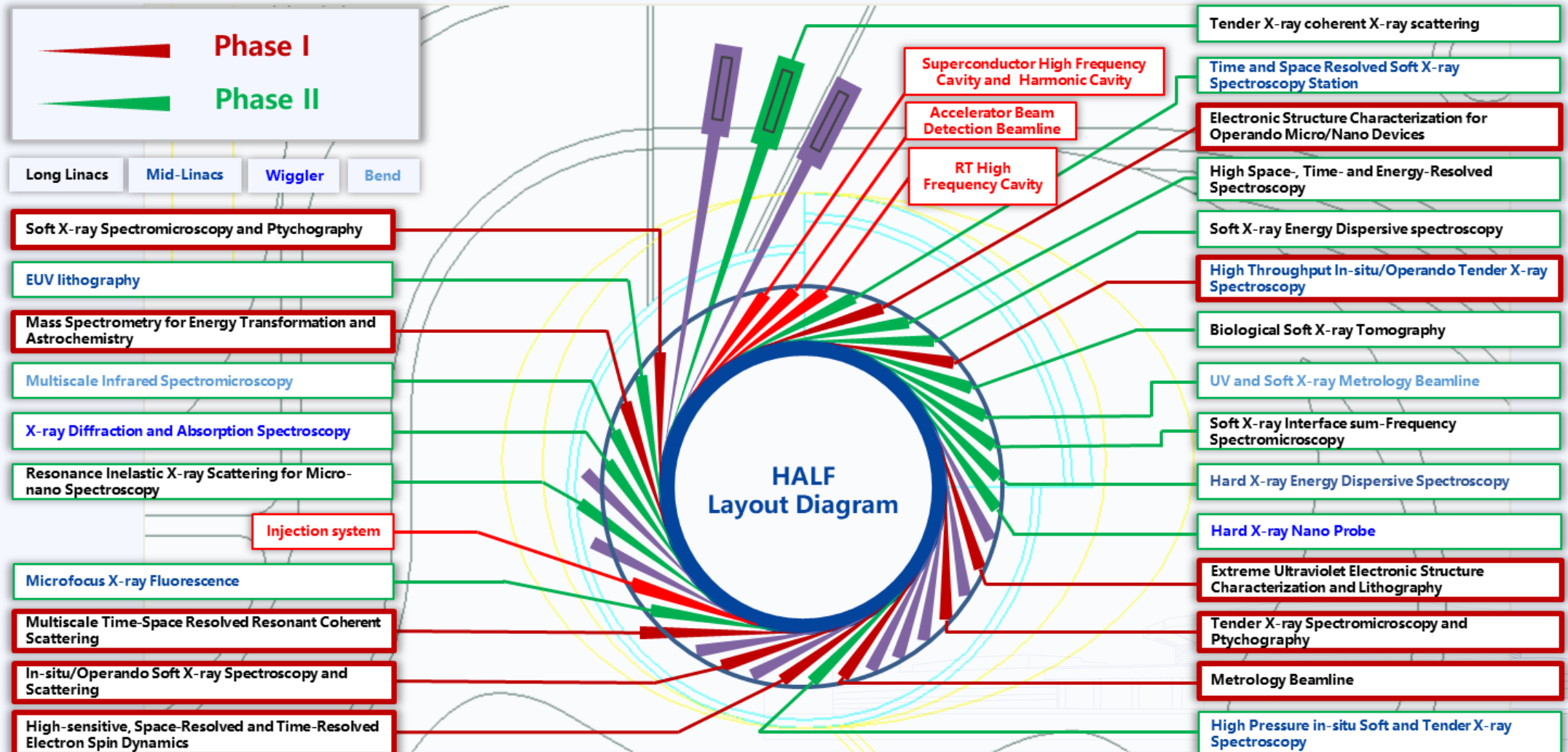

- Green – Already commissioned
- Blue – To be commissioned soon

Type	Ph. /eV	Per. len./mm	Min. gap/ mm	Max K	Length /m	Num.	Status
HU115	5-20	115	14	C 8.89	4.2	1	Commissioned
EPU120	6-135	120	20	H 11.21 V 9.68 C 7.33	4.2	1	Assembling
EPU63	45-1000	63	14	H 5.65 V 4.41 C 3.47	4.2	1	Commissioning
EPU44	250-2000	43.5	14	H 2.94 V 2.08 C 1.70	1.7	2	Manufacturing
EPU46	250-2500	46	14	H 3.24 V 2.36 C 1.90	4.2	1	Near completion
EPU42	250-4000	41.5	14	H 2.65 V 1.85 C 1.51	4.2	1	Commissioned
LPU38b	180-2500	38.5	12	H 3.36	4.2	1	Near completion
LPU38a	250-2000	38.2	12	H 2.83	4.2	1	Commissioning
IVU21a	2100-9000	20.7	6	H 2.10	4.3	1	Commissioning
IVU21b	700-10000	20.7	6	H 2.10	1.5	1	Near completion
Wiggler100	5000-30000	100	12	H 16.0	4.2	2	Commissioned(1)
EPU43	205-3000	42.5	14	H 2.92 V 2.06 C 1.68	4.2	1	Designing
Wiggler120	—	120	12	H 19.6	1.5	1	Designing

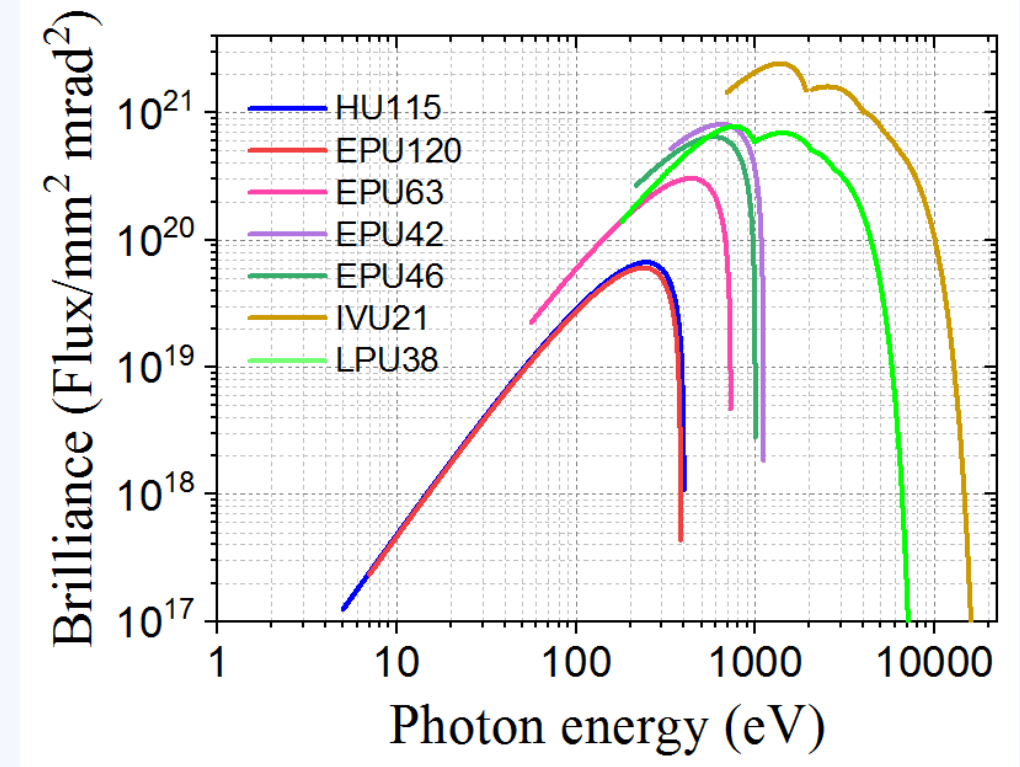
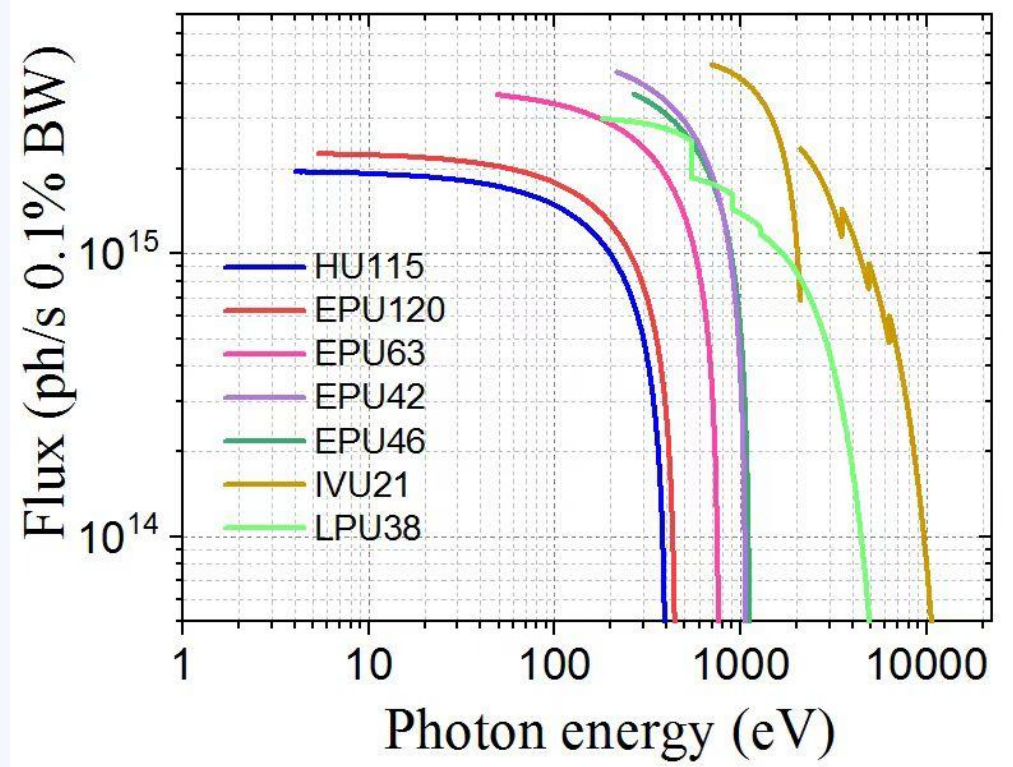

- Advantageous photon energy range lies in the vacuum ultraviolet to soft X-ray region.
- Peak brilliance reaches  $2 \times 10^{21}$  photons/(s·mm<sup>2</sup>·mrad<sup>2</sup>·0.1% BW).

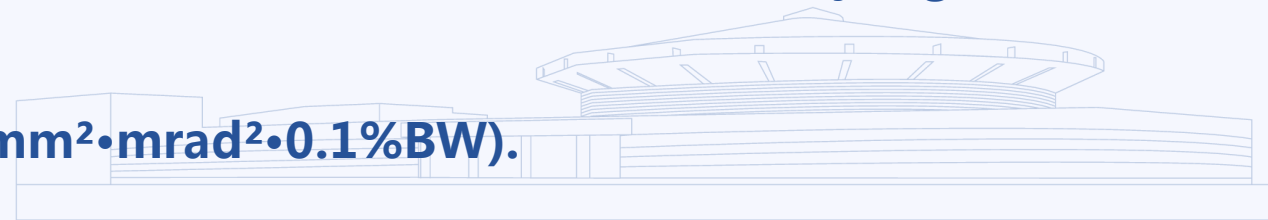

## Storage ring Insertion devices CPM

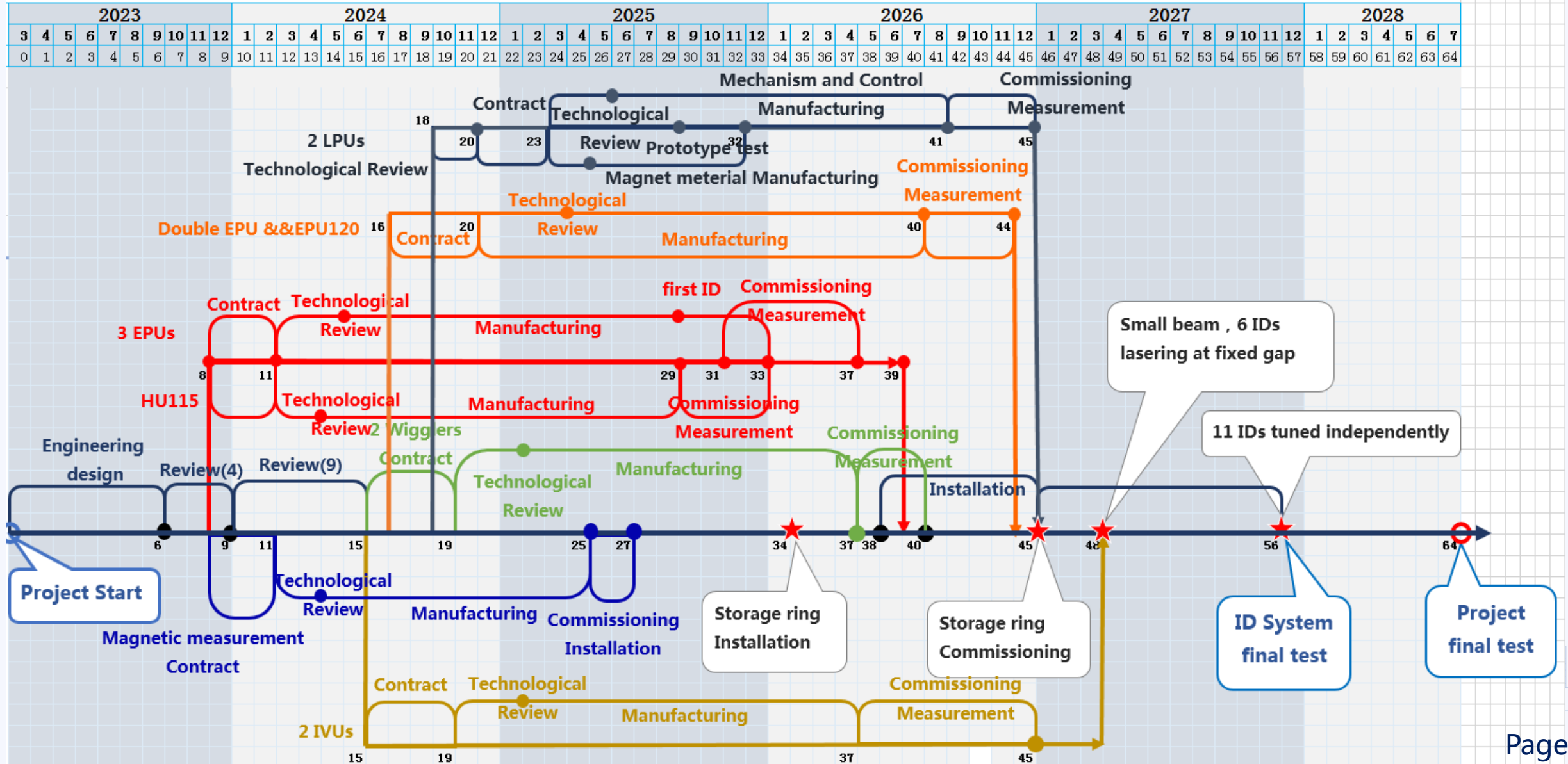

# OUTLINE

01 Overview of Insertion Devices at USTC

**02 ID commissioning for HALF**

03 Future perspectives

04 Summary

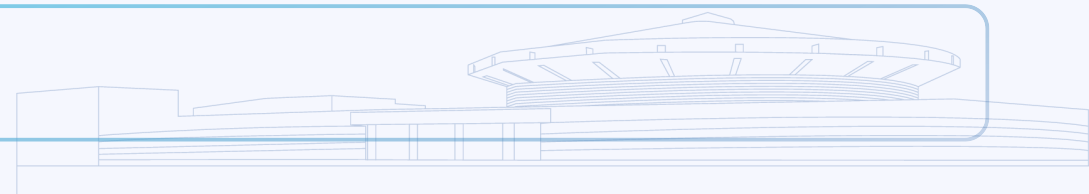

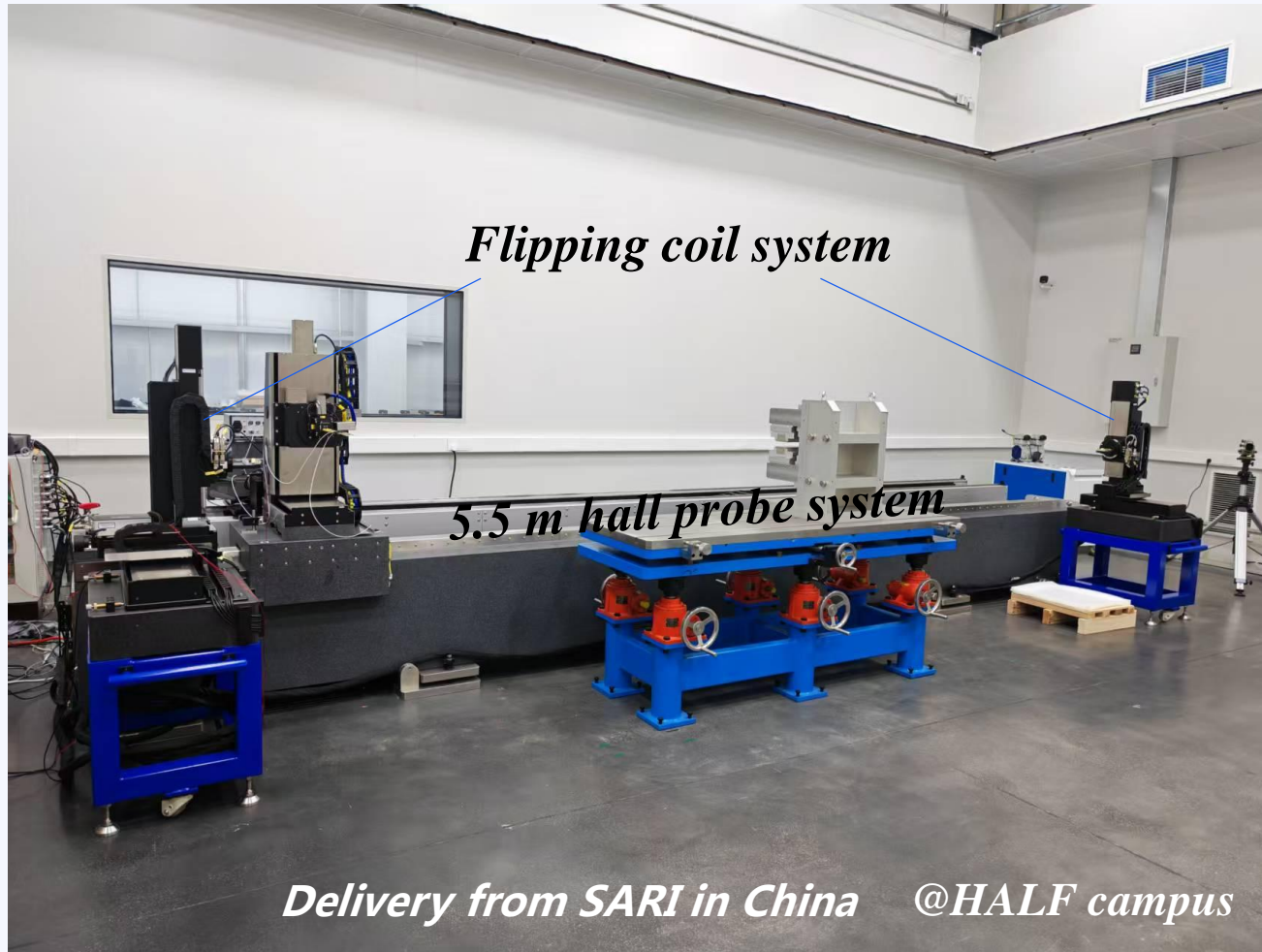

**5.5 m hall probe system:** 6-axis movement, positioning precision  $< 1 \mu\text{m}$ . Two hall probes (3MH6-E, 3MH3-B). Magnetic field repeatability  $< 0.01\%$ .

**Flipping coil system:** 3-axis movement, positioning precision  $< 1 \mu\text{m}$ . Field integral repeatability  $< 5 \text{Gs}\cdot\text{cm}$  and  $< 1000 \text{Gs}\cdot\text{cm}^2$ .



**Features:** Spring-8 type helical undulator, low on-axis heat load, low harmonic radiation, covering 5-20 eV, potential for circular polarization switching.



Mechanical and motion test



Retest

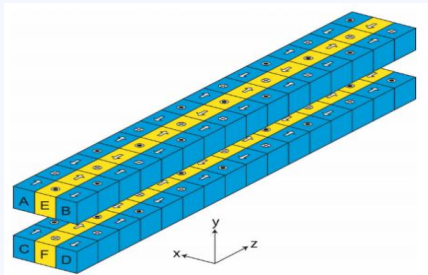
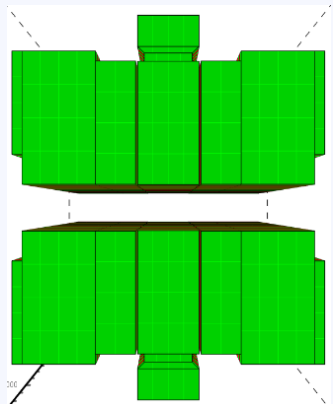
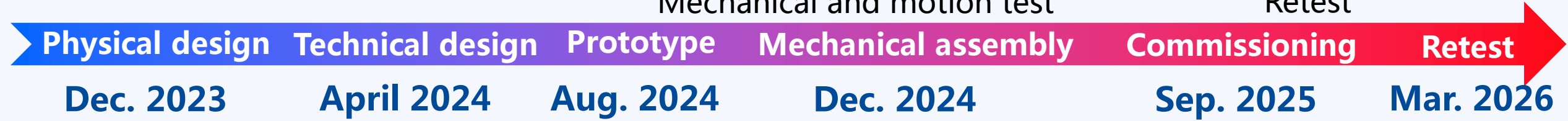

Magnet array



Prototype test



Undulator shimming and test

## Field optimization methods:

- Tuning magnet height
- Exchanging magnet
- Soft iron sheet
- Magic finger
- Correct coil and long coil

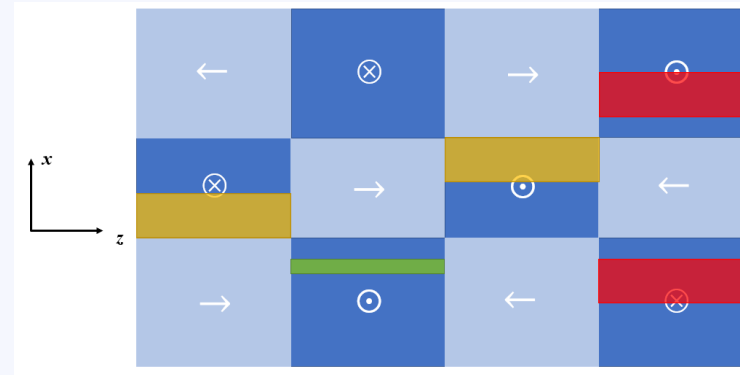

Sheet on surface of magnet block

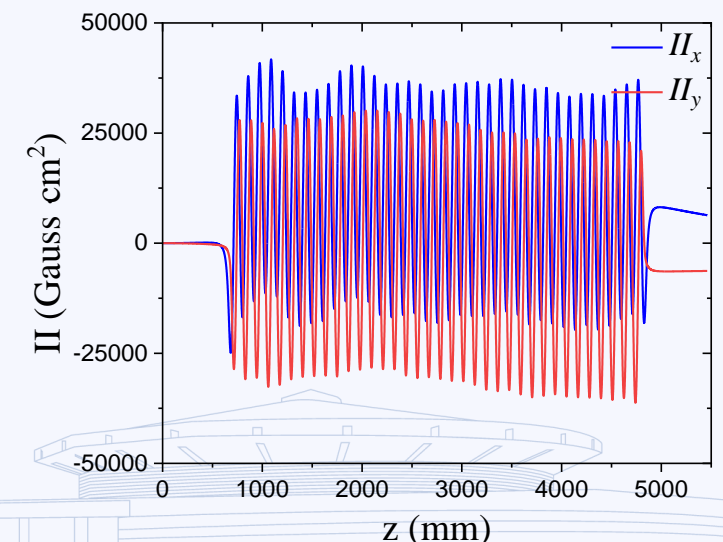
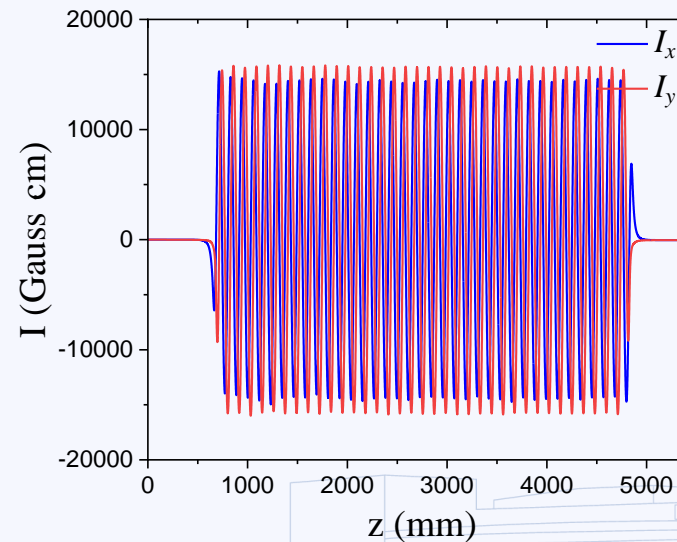
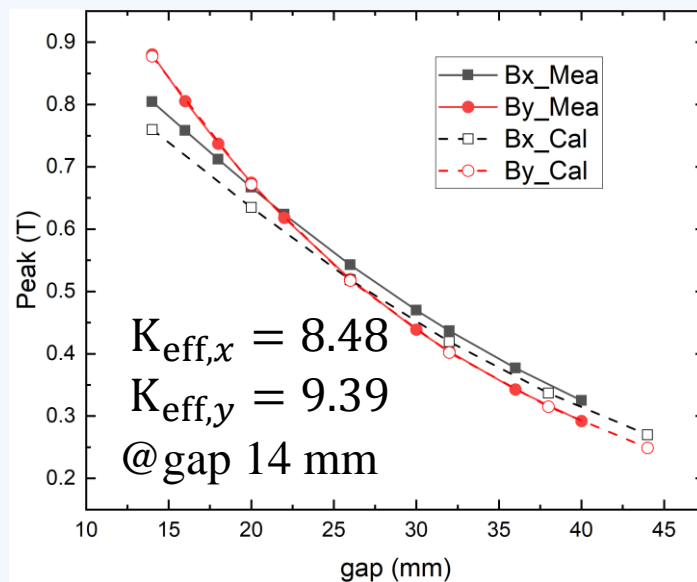
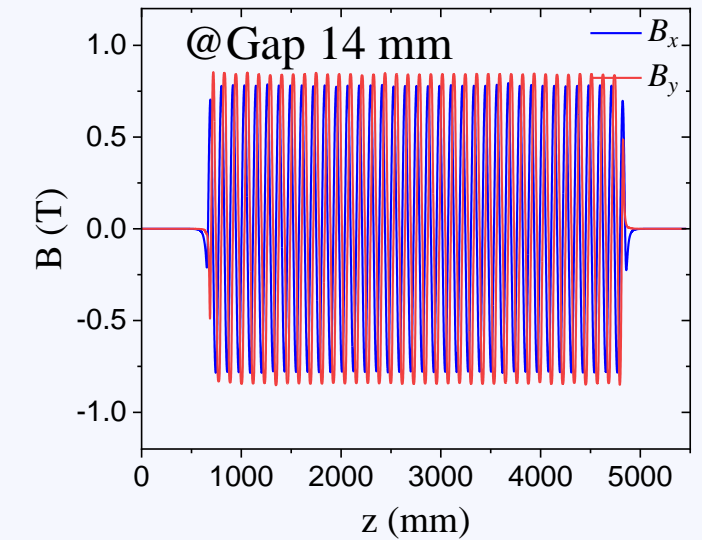

## Measurement brief summary

Item	Measurement @Company	Retest (with coil correction) @HALF campus
Max K	$K_x=8.48, K_y=9.39$	$K_x=8.50, K_y=9.40$
1 <sup>st</sup> field integral (Gs cm) ( $x \leq \pm 13$ mm)@working gap 14-40 mm	$\leq \pm 86$	$\leq \pm 94$
2 <sup>nd</sup> field integral (Gs cm <sup>2</sup> ) ( $x \leq \pm 13$ mm) @working gap	$\leq \pm 16000$	$\leq \pm 25000$
2 <sup>nd</sup> field integral RMS deviation (@ $B_{x,y}=0$ ) (Gs cm <sup>2</sup> ) @working gap	$\leq 1823$	$\leq 1953$
RMS phase error @working gap	$\leq 5.2^\circ$	$\leq 5.3^\circ$

*by flipping coil  
by stretched wire*

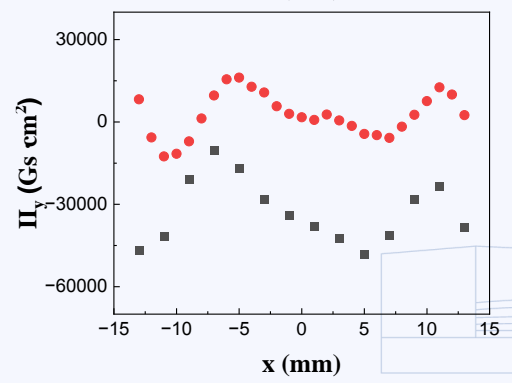
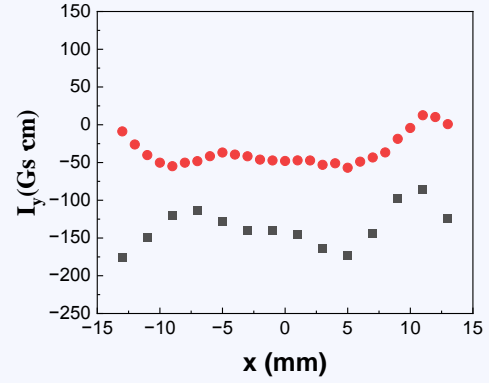
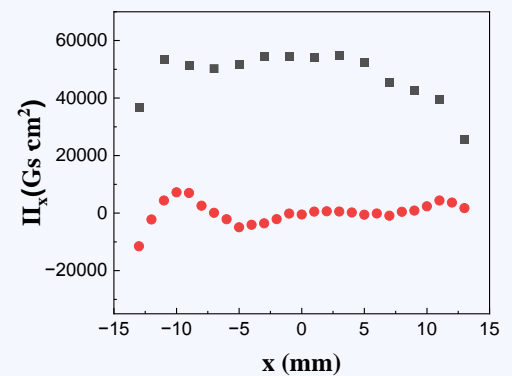
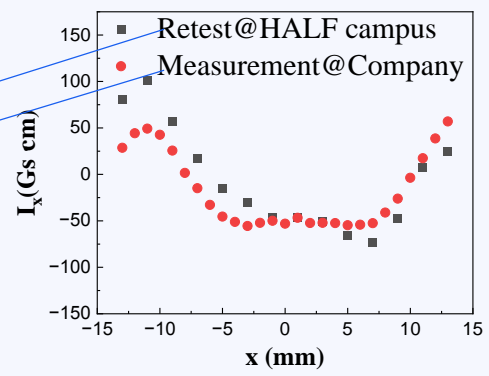

1<sup>st</sup> field integral

2<sup>nd</sup> field integral

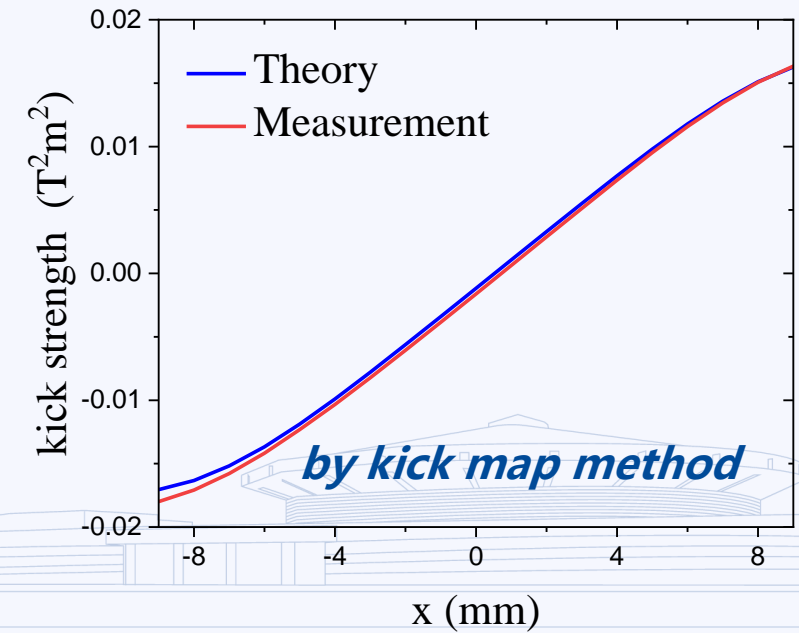

*by kick map method*

**Features:** Traditional APPLE II undulator, arbitrary polarization, covering 250-4000 eV.

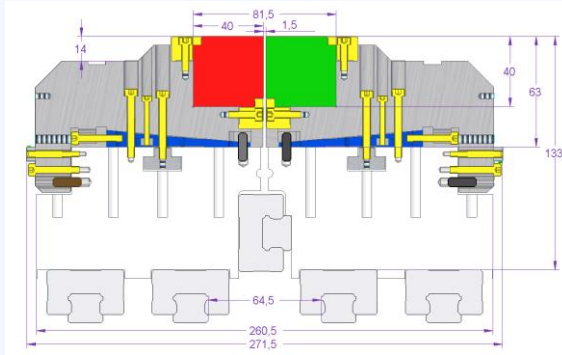

Holder structure

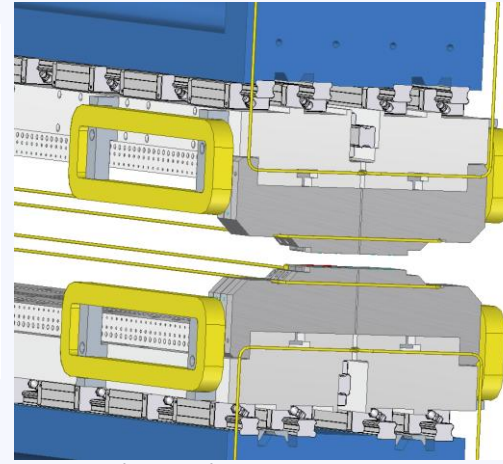

Termination structure



Undulator shimming and test

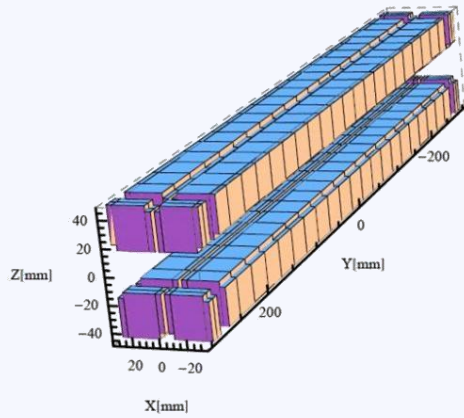

Magnet array



Mechanical and motion test

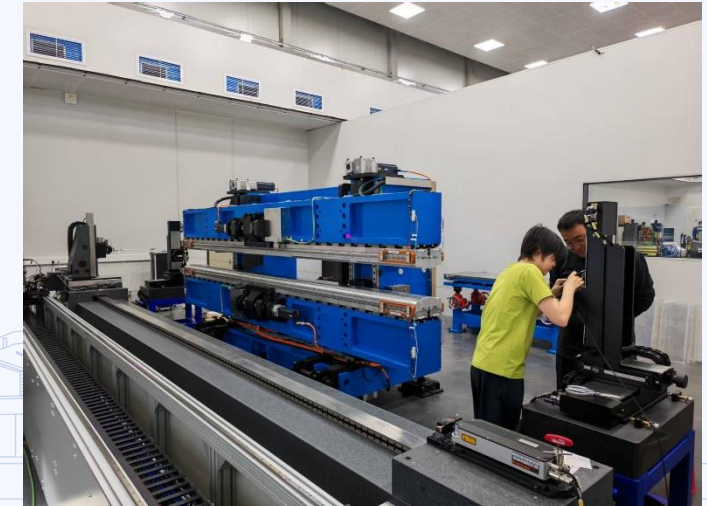

Retest

## Field optimization methods:

- Tuning magnet height/position
- Magic finger (two versions)
- Soft iron sheet
- Correct coil and long coil

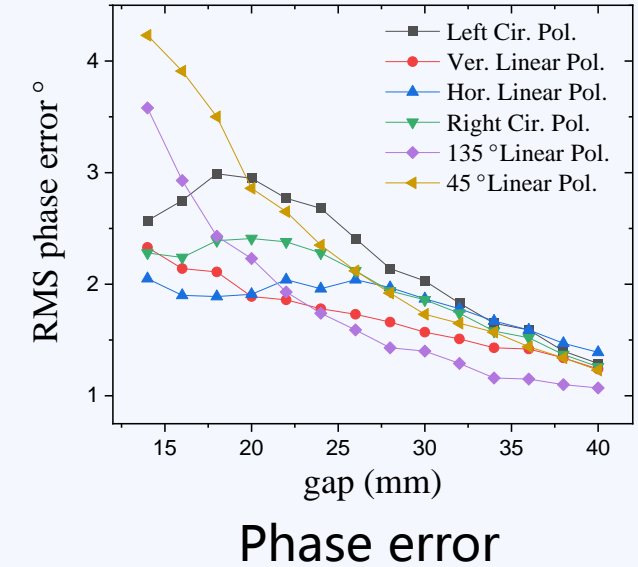
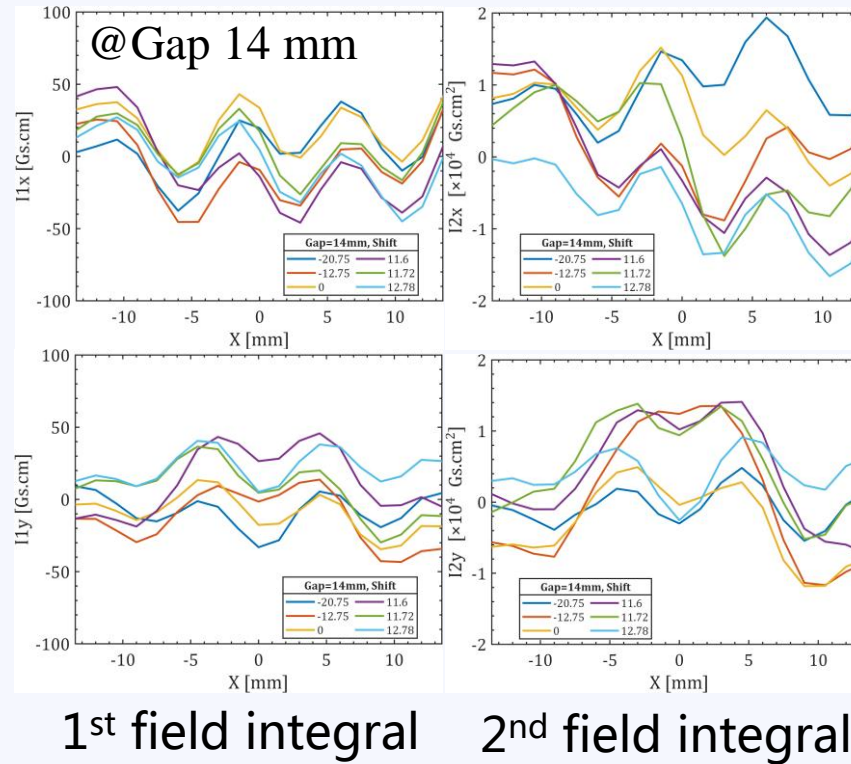

## Measurement brief summary

Item	Measurement @SARI	Retest (with coil correction) @HALF campus
Max K	$K_x=1.90, K_y=2.80, K_x=K_y=1.57$	$K_x=1.90, K_y=2.80, K_x=K_y=1.58$
1 <sup>st</sup> field integral(Gs cm)( $x \leq \pm 13$ mm)@working gap 14-40 mm	$\leq \pm 50$	$\leq \pm 50$
2 <sup>nd</sup> field integral(Gs cm <sup>2</sup> )( $x \leq \pm 13$ mm) @working gap	$\leq \pm 20000$	$\leq \pm 20000$
2 <sup>nd</sup> field integral RMS deviation (@ $B_{x/y}=0$ )(Gs cm <sup>2</sup> ) @working gap	$\leq 1650$	$\leq \pm 2000$
RMS phase error@working gap (14-24 mm)	$\leq 4.2^\circ$	$\leq 4.5^\circ$
RMS phase error@working gap (24-40 mm)	$\leq 2.7^\circ$	$\leq 2.9^\circ$

**Features:** Initially for beam damping, large magnet/pole to obtain a high field ( $> 1.9\text{ T}$  @  $12\text{ mm}$  gap,  $100\text{ mm}$  per. length).

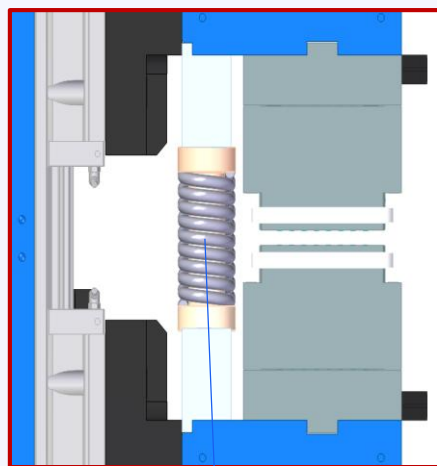

Mechanical spring

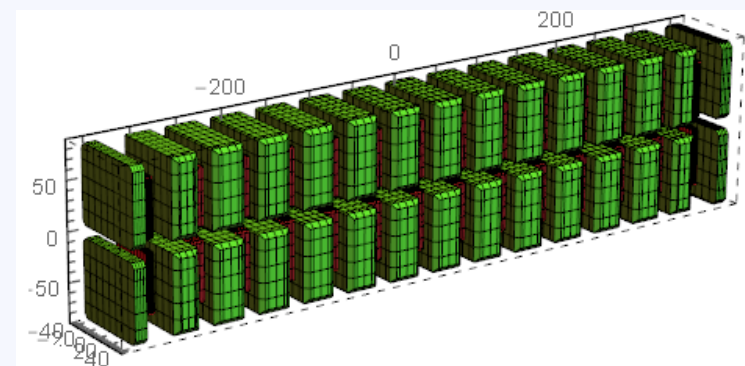
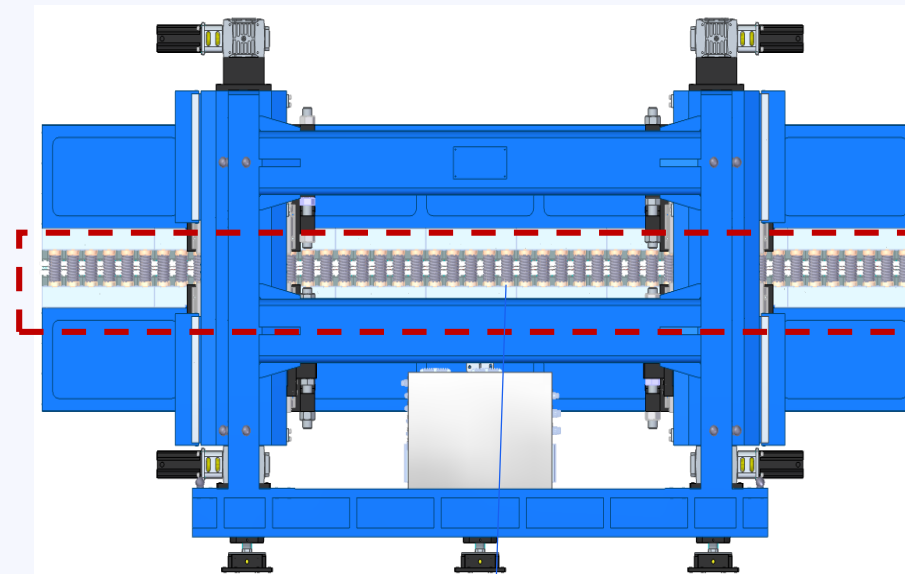

Magnet :  $87\text{ mm} \times 80\text{ mm} \times 34\text{ mm}$   
Pole :  $67\text{ mm} \times 60\text{ mm} \times 16\text{ mm}$

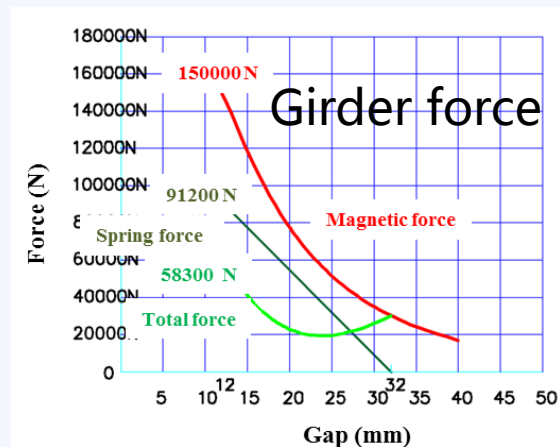

Spring mechanism to compensate magnetic force: Max force reduced from 15 to 6 tons.



Spring fatigue test: Force variation  $\sim \pm 1\%$  after 10000 cycles.

The first wiggler is commissioned recently.

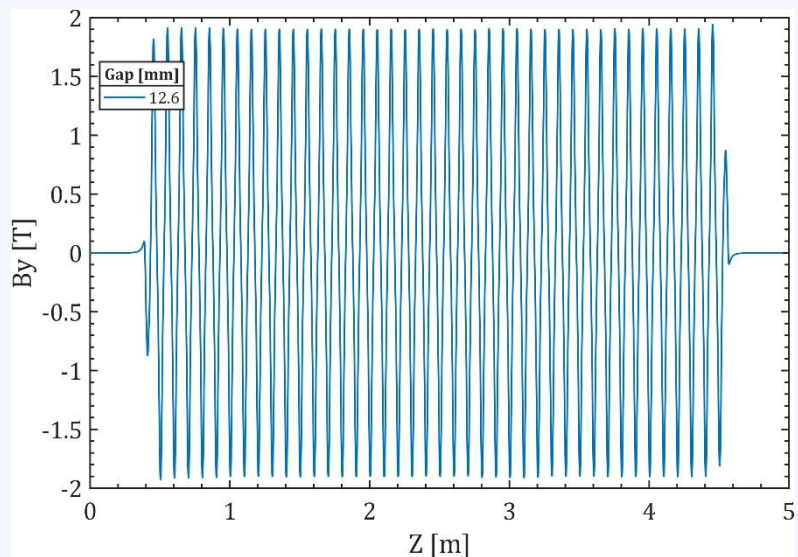

Measurement brief summary	
Item	Measurement@SARI
Max $K$ , Peak $B$	$K=16$ , $B_{effective}=1.71$ T
1 <sup>st</sup> field integral(Gs cm)( $x \leq \pm 13$ mm)@working gap 12-40 mm	$\leq \pm 100$ (with coil correction)
2 <sup>nd</sup> field integral(Gs cm <sup>2</sup> )( $x \leq \pm 13$ mm) @working gap	$\leq \pm 30000$
Peak to peak error	$\leq 0.3\%$

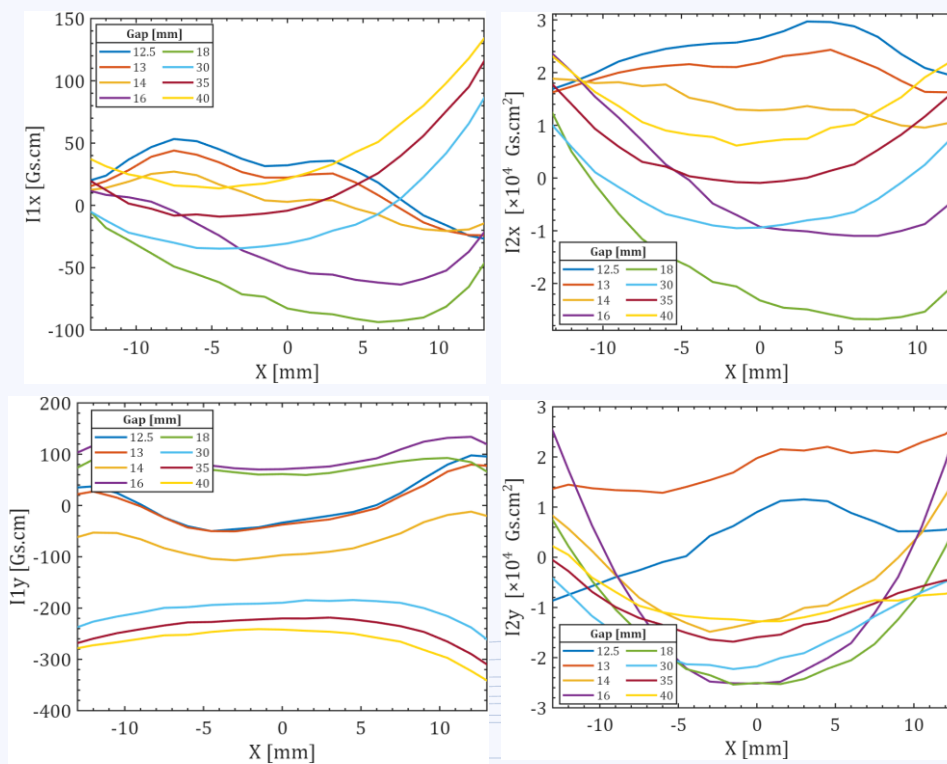

1<sup>st</sup> field integral

2<sup>nd</sup> field integral

Done by SARI and  
USTC in China

**Features:** Covering 700-10000 eV, flux as high as possible, linear polarization, in vacuum.

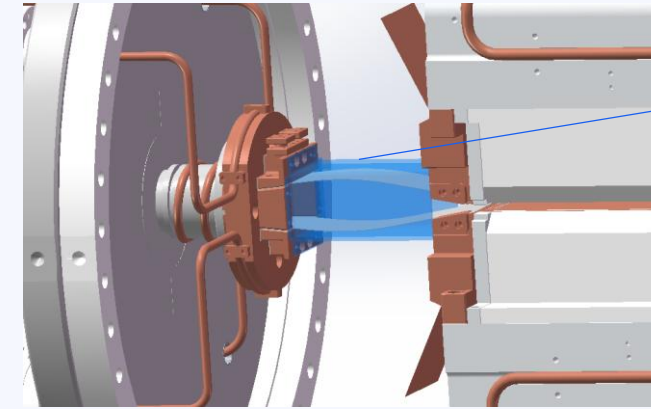
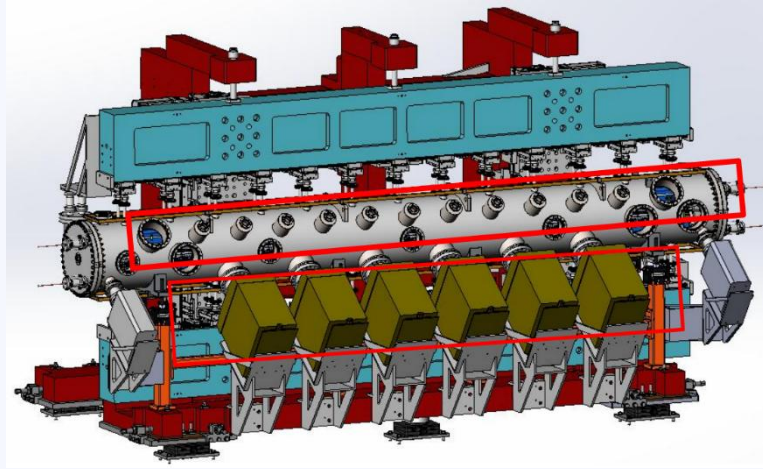

Transition section:  
**Copper box** (gap independent) to reduce vertically trapped mode instability.

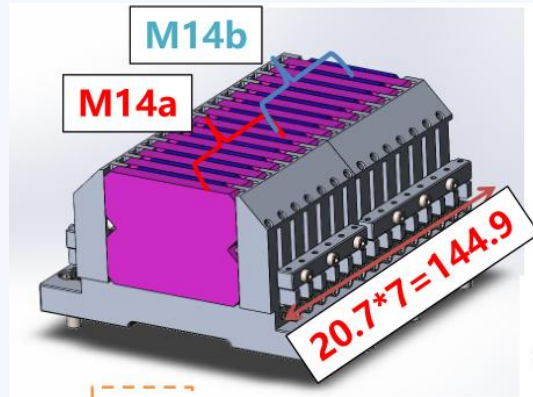
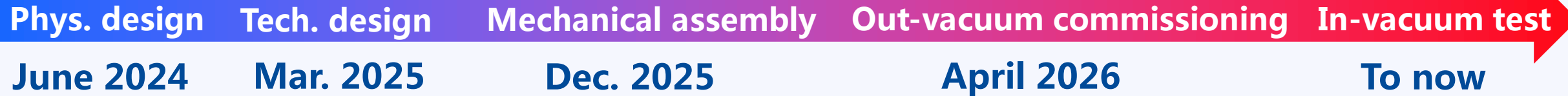

7 or 4 periods@1 Module

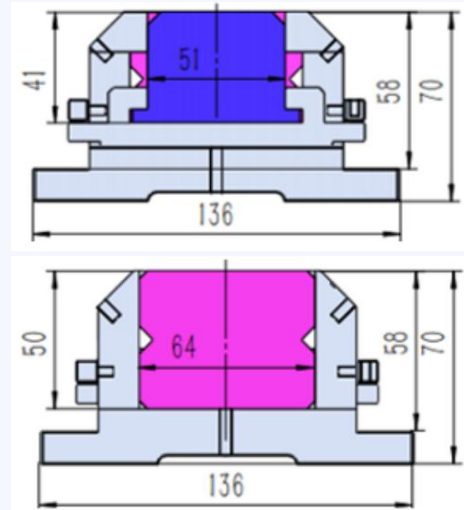

Magnet : 64mm×50mm×7mm  
Pole : 51mm×41mm×3.35mm



IVU21a shimming and test

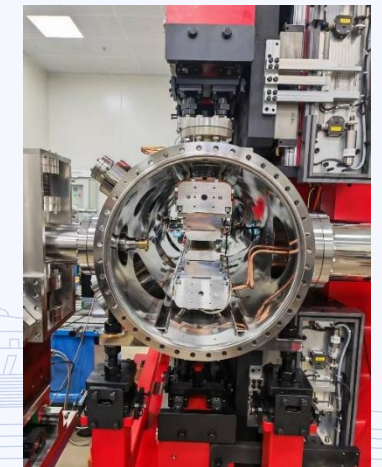

IVU21b vacuum assembly

- The out-vacuum magnetic field shimming and test were completed recently.
- The in-vacuum assembly and test are ongoing.

**IVU21a out-vacuum field measurement summary**

Gap (mm)	$I_x$ [G cm]	$II_x$ [G cm <sup>2</sup> ]	$I_y$ [G cm]	$II_y$ [G cm <sup>2</sup> ]	XB1 [G]	XB2 [G/cm]	XB3 [G/cm <sup>2</sup> ]	YB1 [G]	YB2 [G/cm]	YB3 [G/cm <sup>2</sup> ]	$K_{eff}$	RMS $II_x$ [G cm <sup>2</sup> ]	RMS $II_y$ [G cm <sup>2</sup> ]	RMS Phase error[°]
6	-41	2304	-76	-14281	-1	161	173	1	-39	42	2.09	1195	738	2.65
8	-41	-2786	33	2348	14	62	103	-27	-16	61	1.47	963	757	2.77
10	-32	-2233	21	7545	20	1	45	-23	7	29	1.05	824	667	2.85
16	-14	-1745	-11	8664	16	-30	-21	-14	4	-6	0.41	665	360	0.90
20	-2	43	-23	5998	-1	-13	-27	-20	2	3	0.22	602	314	0.41

**IVU21b out-vacuum field measurement summary**

Gap (mm)	$I_x$ [G cm]	$II_x$ [G cm <sup>2</sup> ]	$I_y$ [G cm]	$II_y$ [G cm <sup>2</sup> ]	XB1 [G]	XB2 [G/cm]	XB3 [G/cm <sup>2</sup> ]	YB1 [G]	YB2 [G/cm]	YB3 [G/cm <sup>2</sup> ]	$K_{eff}$	RMS $II_x$ [G cm <sup>2</sup> ]	RMS $II_y$ [G cm <sup>2</sup> ]	RMS Phase error[°]
6	38	6600	0	4469	33	160	0	9	-39	0	2.13	64	76	1.73
8	43	6722	-30	68	30	62	24	-25	-15	52	1.51	47	181	1.77
10	46	8897	-45	63	26	0	15	-26	6	46	1.08	50	239	1.61
16	35	5433	-60	-1530	13	-29	-5	-15	3	-3	0.42	85	280	0.84
20	27	3922	-63	-1930	-4	-12	-14	-17	2	-9	0.23	101	272	0.49

**Done by HE-Racing Technology Co., Ltd and USTC in China**

# IVU21a & IVU21b

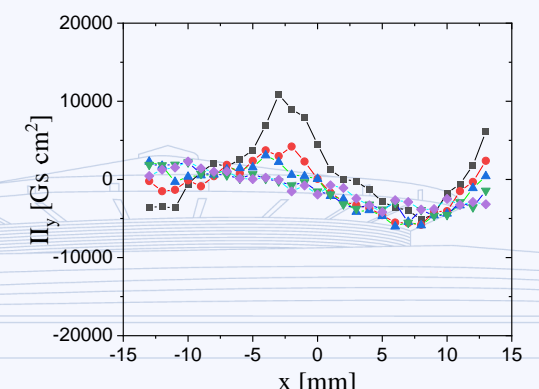
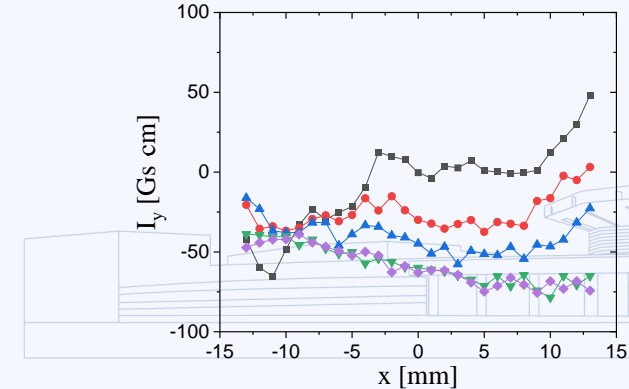
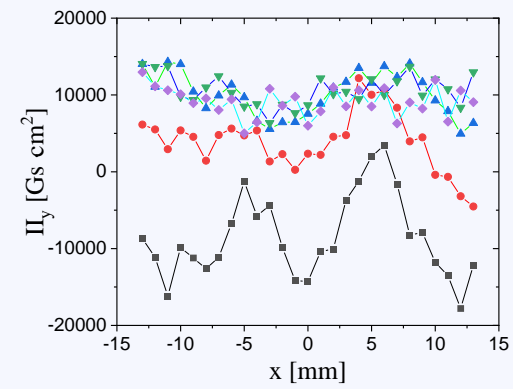
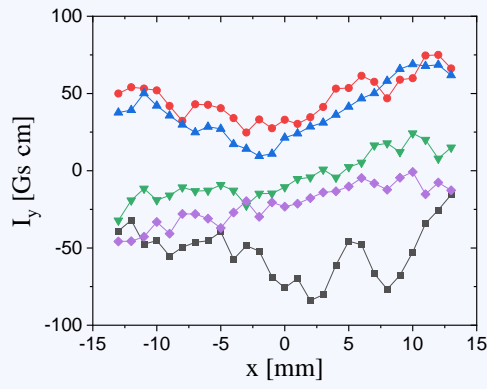
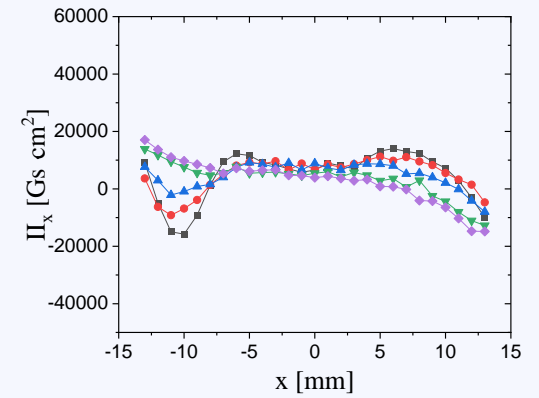
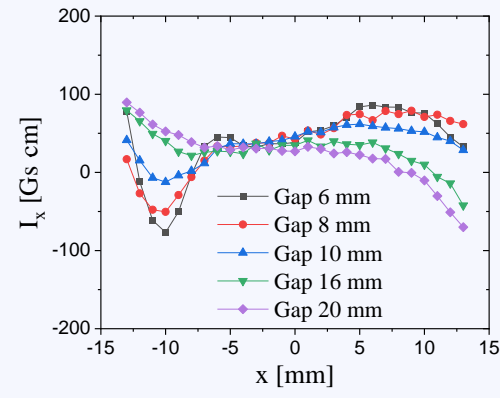
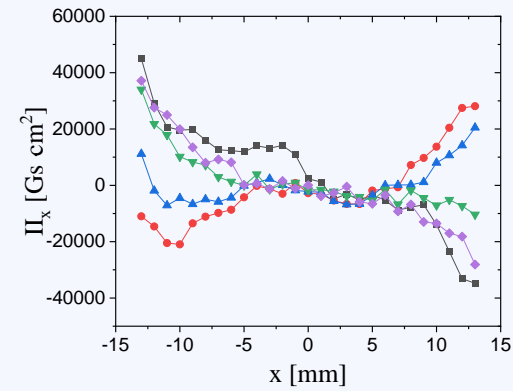
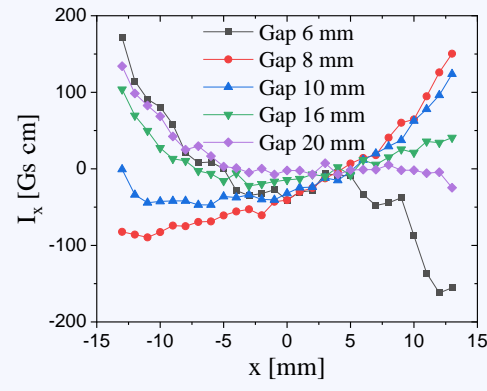
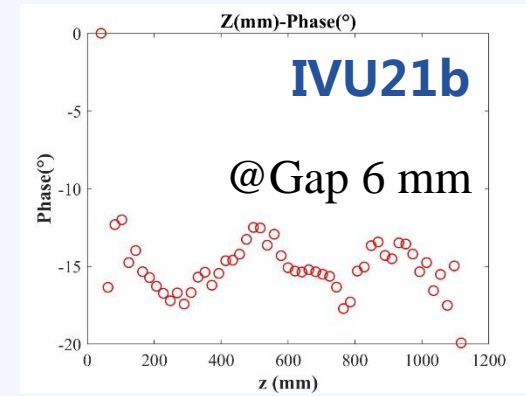
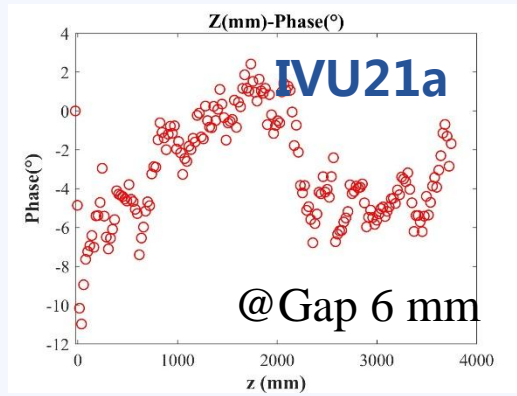

1<sup>st</sup> field integral

2<sup>nd</sup> field integral

1<sup>st</sup> field integral

2<sup>nd</sup> field integral

**Features:** Covering 180/250-2500 eV, linear polarization, **fully self-developed**.

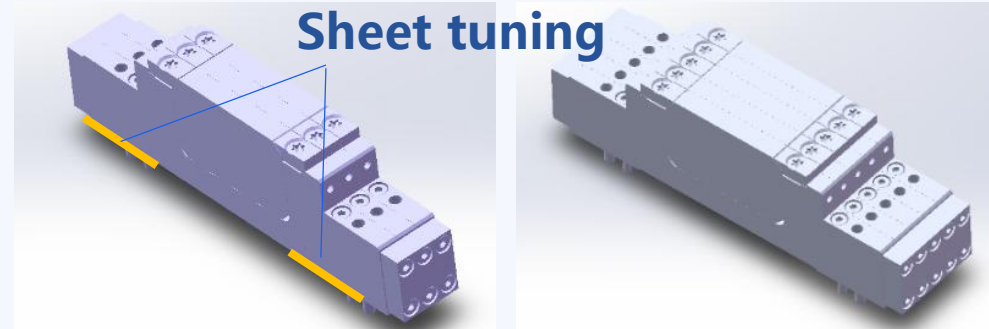

Pure permanent magnet (LPU38a)

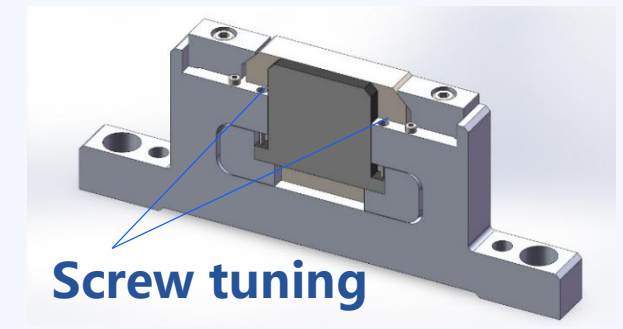

Hybrid magnet (LPU38b)

Physical design   Technical design   Prototype   Mechanical assembly   Magnetic commissioning

June 2024

Oct. 2024

Sep. 2025

April 2026

To now

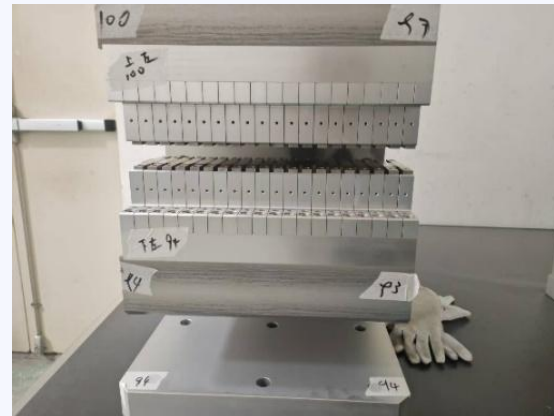
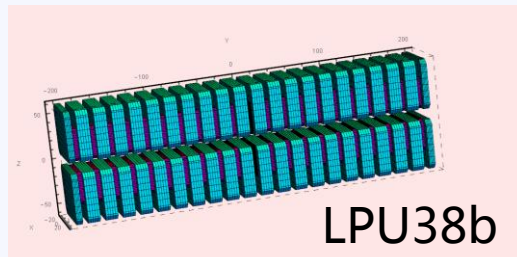
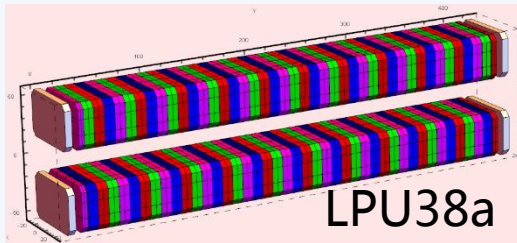

## Technologies developed:

- ✓ Different sorting algorithms for pure permanent, hybrid and EPU undulators.
- ✓ Magnetic field analysis considering magnet & mechanical error, force-induced deformation, demagnetization.
- ✓ Design principles for magnet holders, terminations, magic fingers and girders.
- ✓ Compensation models for undulator dynamic field integrals based on kick map, including Genetic Algorithm, Simulated Annealing and Newton-Raphson methods.
- ✓ Optimization methods for undulator shimming.

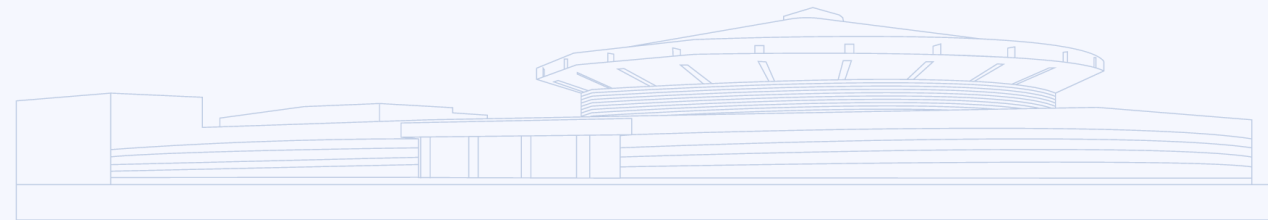



LPU38b under commissioning

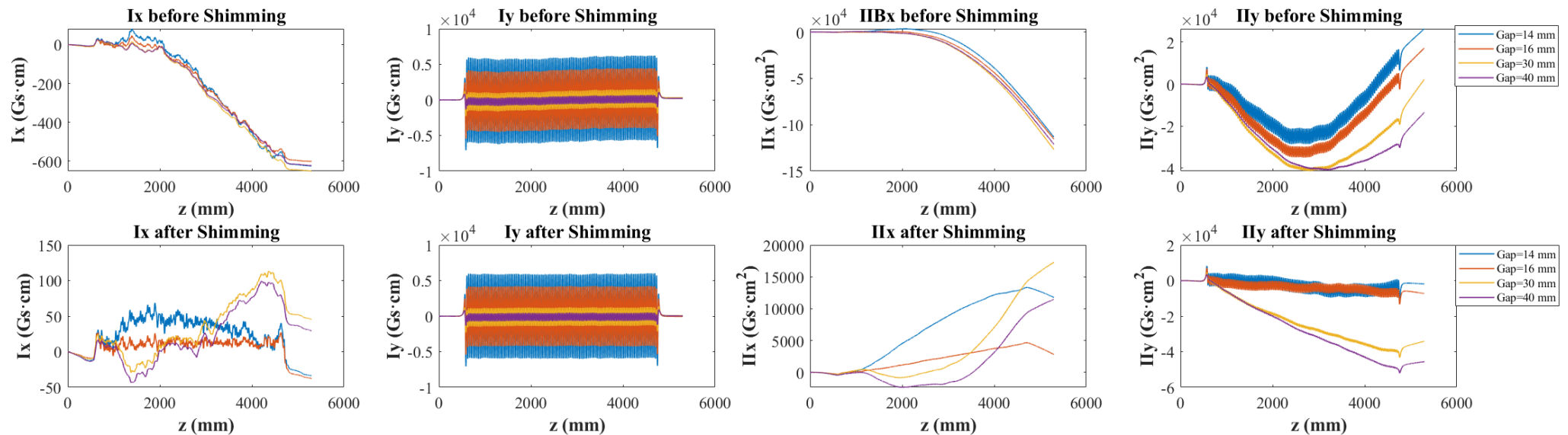
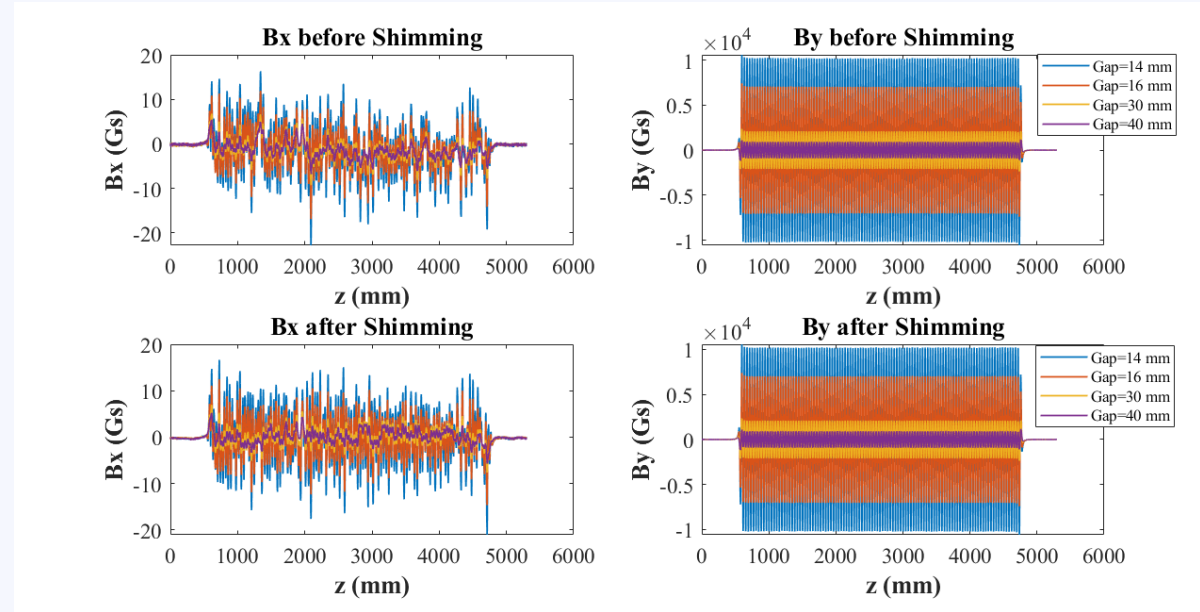

Gap (mm)	14		16		30		40	
	Before shimming	After shimming	Before shimming	After shimming	Before shimming	After shimming	Before shimming	After shimming
B (T)	1.02	1.02	0.70	0.70	0.21	0.21	0.09	0.09
Peak to peak RMS error(‰)	2.79	2.26	2.65	2.18	3.57	2.98	5.58	4.38
K	3.51	3.52	2.48	2.47	0.76	0.75	0.34	0.33
<b>RMS Phase Error (°)</b>	<b>15.31</b>	<b>7.93</b>	<b>15.83</b>	<b>2.68</b>	<b>23.73</b>	<b>2.67</b>	<b>16.21</b>	<b>2.69</b>
$I_x$ (Gs cm)	-626.87	-33.94	-602.59	-37.76	-652.11	45.37	-623.94	29.22
$I_y$ (Gs cm)	197.75	-18.90	214.31	-43.48	299.76	63.94	228.82	34.43
$II_x$ (Gs cm <sup>2</sup> )	-113421.81	11754.05	-115513.18	2787.13	-126798.30	17287.58	-121197.66	11457.53
$II_y$ (Gs cm <sup>2</sup> )	26353.86	-1931.11	17200.48	-7318.49	2287.64	-34131.09	-13506.32	-45603.11
$II_y$ RMS deviation (Gs cm <sup>2</sup> )	18678.08	1177.03	21622.77	955.76	21251.91	3817.51	16119.93	1822.24

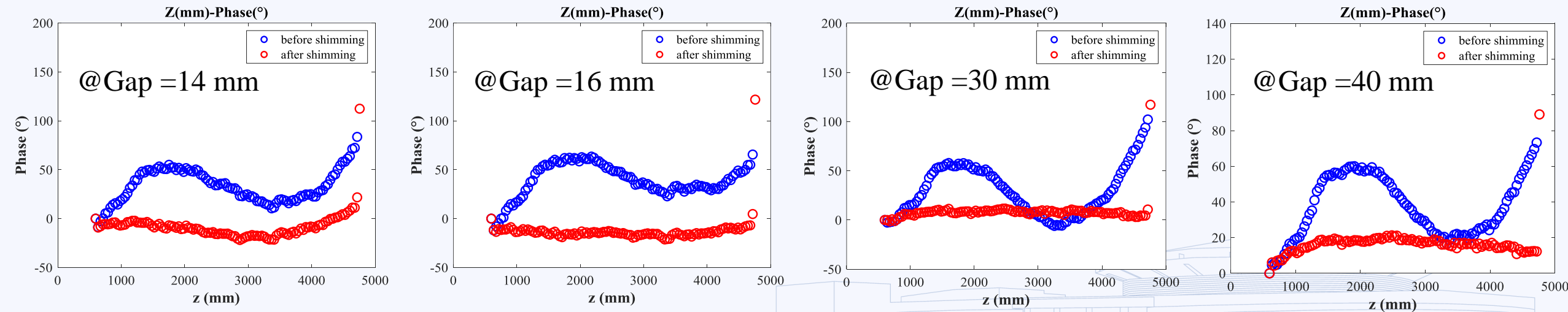

- LPU38b is under commissioning (first round shimming completed, second round in progress).
- Commissioning for LPU38a will begin after LPU38b.

## Compensate the multipole field induced by IDs

**Features:** Pasting on ID vacuum chamber surface, all EPU and HU employ the current strips, 28 strips for each ID.

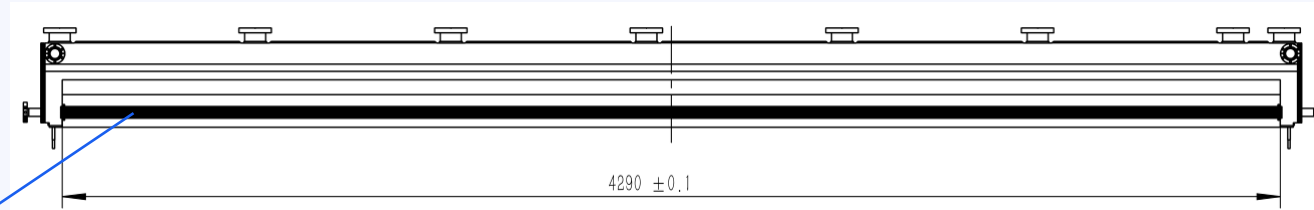

ID vacuum chamber  
Current strips for IDs

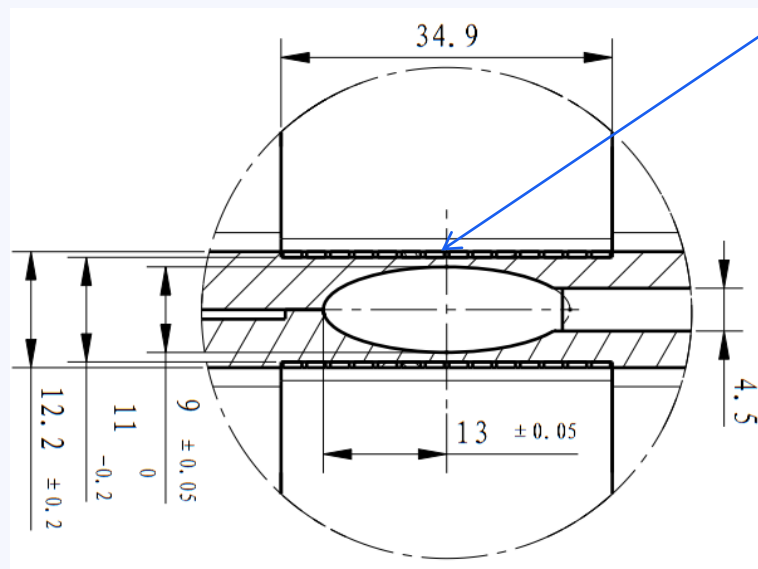

Cross section of  
ID vacuum chamber

ID	Min. gap (mm)	Width (mm) × Height (mm)	Strip Number	Power Supply
EPU120	20	2 × 1	28	28
HU115	14	2 × 0.4	28	28
EPU63	14	2 × 0.6	28	14
EPU46	14	2 × 0.6	28	14
EPU42	14	2 × 0.6	28	14
EPU44	14	2 × 0.6	28	14





EPU46/EPU63: Magnetic commissioning

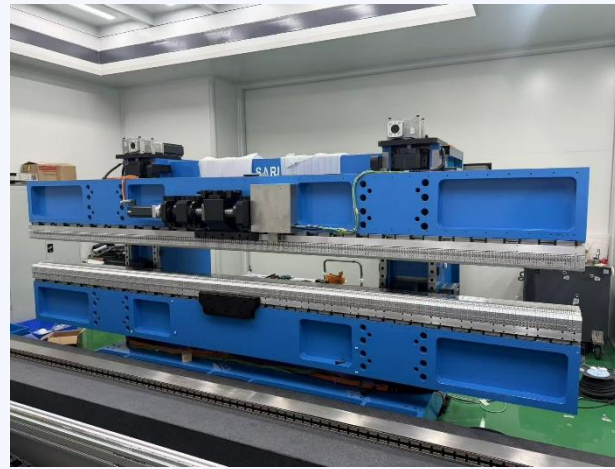

EPU120: Assembling



Double EPU44: Awaiting assembly

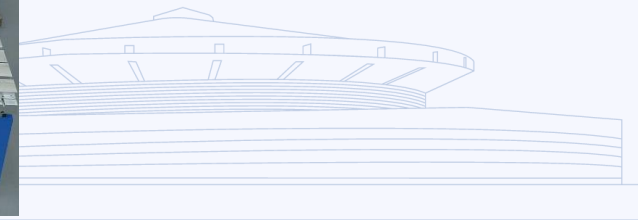

# OUTLINE

01 Overview of Insertion Devices at USTC

02 ID commissioning for HALF

**03 Future perspectives**

04 Summary

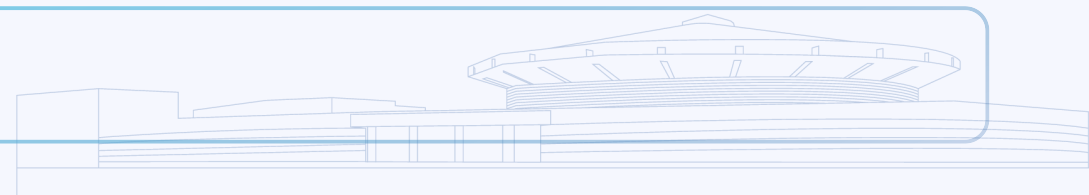

## Engineering goals:

- **Complete commissioning of all IDs by 2026.**
- **Install 11 IDs in storage ring by Dec. 2026, and 2 IVUs together with superconducting main RF cavity by Apr. 2027.**
- **Achieve lasing at fixed gap by Apr. 2027, and independent gap/phase motion by Nov. 2027.**
- **Advance R&D of a new EPU independently by USTC within the next two years.**
- **Prepare ID plan for HALF Phase II.**

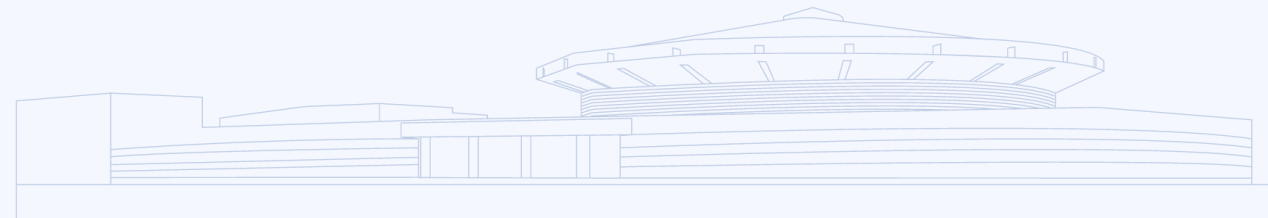

## Research goals:

- R&D of a prototype for strong tapered beat-frequency undulator.

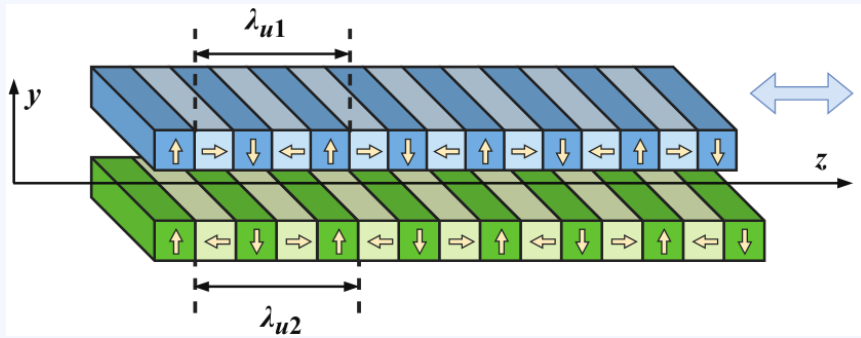

Novel strong tapered undulator

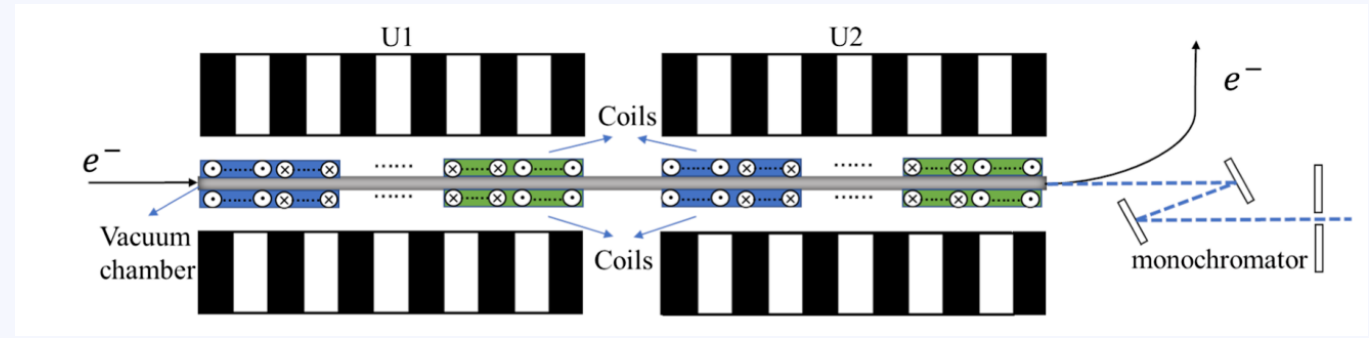

Novel fast polarization switching scheme

- R&D of a fast polarization switching ( $\sim$  kHz) scheme based on field modulation.

- Advanced ID schemes: APPLE-KNOT, enhanced on-axis harmonic circularly polarized radiation, etc.



- ID field measurement system, HU115, EPU42 and the first Wiggler100 are already commissioned – test results are satisfactory.
- Remaining IDs are in commissioning or assembly stages.

*We greatly thank SARI, IHEP, and all experts worldwide for their kind support. We look forward to future collaboration on various aspects of ID development.*

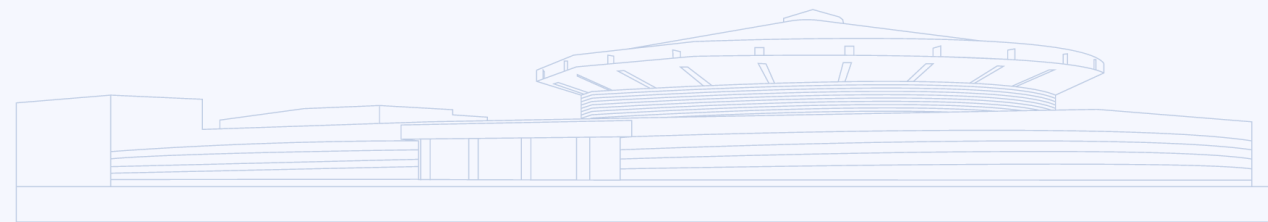



University of Science and Technology of China  
National Synchrotron Radiation Laboratory

---

**THANKS!**

